



MG Motor

# 7/11kW AC EV Charger MG ChargeHub

## Instruction Manual



**“WARNING”, WHICH INDICATES A HAZARD**

Pay attention to personal injuries or death caused by operation steps, practice or incorrect implementation. The operation after the “warning” sign can only be performed when the conditions are fully understood and satisfied.

---

**“CAUTION”, WHICH INDICATES A HAZARD.**

Pay attention to the damaged or destroyed product caused by the operation steps, experiments or incorrect execution. Only after fully understanding and satisfying the indicated conditions, the operation after the “caution” mark can be performed.

---

**“HINT”, WHICH INDICATES SKILL OR USEFUL INFORMATION**

Skills and useful information are marked as “Hint”. It does not contain information that warns of dangerous or harmful features.

---

**“GARBAGE DISPOSAL”, WHICH INDICATES ELECTRICAL AND ELECTRONIC WASTE**

This symbol is located on the product, in the instruction manual or on the packaging, indicating that the electrical and electronic equipment and its accessories should be disposed separately from ordinary household waste.

Materials can be reused based on their markings. By reusing old equipment, materials and other forms of reuse, you can make a significant contribution to the environment.



---

# Contents

1. Key Information	4
1.1 Safety Instruction	4
2. Product Overview	7
2.1 Product Features	7
2.2 Product Functions	8
2.3 Technical Characteristics	8
3. Operation Instruction	9
3.1 Appearance Introduction	9
3.2 Start-up charger	11
3.3 End Charging	11
3.4 Indicator Description	12
4. Troubleshooting	13
5. Routine Maintenance	14
5.1 Power distribution system	14
5.2 Wiring System	14
5.3 Circuit Components	14
5.4 Auxiliary System	15
5.5 Electrical Ground System	15
5.6 Appearance	15
5.7 Maintenance Period	16
6. Customer Service	17
6.1 Preparation	17
6.2 Contact Information	17
A. Installation Instruction	18
A.1 Installation Requirements	18
A.2 Power Supply Requirements	19
A.3 Environmental Requirements	19
A.4 Wiring Requirements	19
A.5 Product Installation	20

B. Web Configuration Instruction	29
B.1 Login into web configuration	30
B.1.1 Via WiFi	30
B.1.2 Via Ethernet cable	30
B.1.3 Via Ethernet cable method 2	34
B.2 Setting charging mode	37
B.2.1 Plug and Play (default mode)	38
B.2.2 Enable by RFID Card	39
B.3 Connect to the Internet	40
B.3.1 Using SIM card	40
B.3.2 Using WiFi STA	41
B.3.3 Using Ethernet cable	43
B.3.4 Check Internet Connection	43
B.4 Connect to OCPP Platform	44
B.5 Restore to Factory Setting	46
D. Appendix	47
E. Warranty Policy	48
F. Equipment Accessories	50
F.1 Equipment Accessories List	50

# Instruction Manual

SYMBOL	CONTENT
	<p>Failure to follow safety instructions can result in death, injury, and equipment damage. Refuse to bear any claims arising from this.</p> <ul style="list-style-type: none"><li>• <b>ELECTRICAL HAZARD</b></li></ul> <p>Only trained, qualified and authorized electrical professionals are responsible for installation.</p> <ul style="list-style-type: none"><li>• The first time to commission and maintain the charger, it should comply with existing standards and installation regulations when performing the aforementioned operations. See chapter “A Installation Instructions” for details.</li><li>• <b>ELECTRICAL HAZARD / FIRE HAZARD</b><ul style="list-style-type: none"><li>• Must regularly check the charging connector (including cable) in charger for damage and check whether the case is damaged (visual inspection).</li><li>• If the charger is damaged, it must be turned off and replaced immediately.</li><li>• Do not perform the charger maintenance work without authorization. Only the manufacturer can perform the operation (replace the charger).</li><li>• Do not modify or modify the charger.</li><li>• Never remove signs such as safety symbols, warnings, nameplates, signs or pipeline markings.</li></ul></li><li>• No extension cable shall be used when connecting the electric vehicle to the electric vehicle power supply device.</li><li>• Only connect electric vehicles or their charging equipment. Do not connect other loads (power tools, etc.).</li><li>• Hold the connector when pulling the charging connector, and do not pull the cable.</li><li>• Do not bend, squeeze or tilt the charging connector so that it is mechanically damaged.</li><li>• Do not touch the heat source, dirt or water on the contact surface.</li><li>• Some vehicles may generate toxic or explosive gases in the indoor area during charging, so an external ventilation system must be provided.</li><li>• When using an integrated charger to charge your electric car, please read the vehicle's tips and instructions carefully.</li></ul>
	<p><b>CAUTION</b></p> <ul style="list-style-type: none"><li>• Damage hazard.</li><li>• Never use spray water to clean the charging point (Hose for garden watering, high pressure cleaners, etc)</li></ul>

## 1.2 SPECIFIED USE

- This product is AC charger that can charge electric powered vehicles (for example, an electric car) in indoor and outdoor areas.
- When installing and connecting the charger, follow local regulations.
- The intended use of the equipment includes, in all cases, the environmental conditions established for the equipment.
- The storage of charger should be met the following requirements:
  - Before the equipment installation, the charger with components should be stored in the indoor dry and ventilated place. The warehouses' temperature is between -40°C and +85°C, the monthly average relative humidity is not exceeded 90%, and there is no corrosive or explosive gas. During the storage, please avoid rain, exposure, condensation and frost.
  - After the equipment installed, the charger shell should be kept sealed to avoid raining and soaking.
- The equipment is developed, produced, inspected and filed according to relevant safety standards. Therefore, if the instructions and safety technical instructions for the intended use are observed, the product will not cause damage to property or endanger the health of the person under normal circumstances.
- The instructions contained in this manual must be strictly observed, otherwise there may be a safety hazard or the device may fail. Although this manual describes the relevant safety instructions, it is important to pay attention to the safety regulations and accident prevention regulations when the charging equipment is used.
- Due to technical and legal restrictions, it is not possible to supply all models to all countries and regions.



## 1.3 ABOUT THIS MANUAL

- This manual applies to MG ChargeHub
- This manual is for the following people:
  - End customer (AC charger user).
  - Debugging and service technicians.

# 2. Product Overview

## 2.1 PRODUCT FEATURES

### CHARGEHUB 7/11 SPECIFICATIONS

GENERAL	Model Name	ChargeHub 7	ChargeHub 11
POWER INPUT	Input Rating	230Vac±10%, 45-65Hz, single-phase	400Vac±10%, 45-65Hz, three-phase
	Number of Phase/Wire	L+N+PE	L1+L2+L3+N+PE
	Internal RCD	DC 6mA + AC 30mA	DC 6mA + AC 30mA
POWER OUTPUT	Output Power	7kW max.	11kW max.
	Output Current	32A max.	16A max.
	Charging Interface	IEC 62196-2 Type 2 tethered plug	
USER INTERFACE & CONTROL	Status Indicators	RGB LED	
	Buttons and Switch	Emergency stop button	
	Card Reader	ISO/IEC 14443 A/B Mifare RFID reader	
COMMUNICATION	Network Interface	4G, Ethernet, Wi-Fi, RS485	
	Charging Protocol	OCPP1.6j	
ENVIROMENTAL	Operating Temperature	-30°C - 50°C	
	Storage Temperature	-40°C - 70°C	
	Humidity	5% - 95% no condensation	
	Altitude	≤ 2000 m	
MECHANICAL	Ingress Protection	IP55	
	Enclosure Protection	IK10	
	Cooling	Natural cooling	
	Dimension (WxHxD)	282 x 409 x 148 mm	
	Weight	Approx. 4.5kg	Approx. 5.6kg
	Connection	Tethered Type 2 (5m Cable)	
	Installation	Wall-mounted, Column-mounted	
REGULATION	Certificate / Compliance	 	

## 2.2 PRODUCT FUNCTIONS

1. Charging function: During the charging process, the charger can identify the connection state between the charger and the vehicle end, and according to this state, the vehicle can be guided to perform safe charging. The vehicle can control the start and stop of charging.
2. The charger controller has the functions of measurement, control and protection for the charger.
  - 3) With lightning protection, overload protection, short circuit protection, leakage protection, over voltage protection, under voltage protection and grounding detection.
3. Charger supports OCPP 1.6J communication protocol, and the charger can be linked to the data service platform and management platform (Cloud platform) of OCPP 1.6J.
4. The charger can keep normal working status when used in outdoor environment (Protection level is IP55, IK10).

## 2.3 TECHNICAL CHARACTERISTICS

### 1) Charging method:

- Use the mobile APP (from OCPP platform) to scan the charging QR code for charging.
- Swipe the RFID card to start charging.
- Set it as Plug & Play, which is the default mode.

### 2) Build-in electrical protection.

### 3) Suitable for all vehicles complying with IEC 62196-2.

### 4) Output power configuration: support output power configurable (Maximum output current set by DIP switch, single-phase 6A-32A, three-phase 6A-16A).



# 3. Operation Instruction

## 3.1 APPEARANCE INTRODUCTION

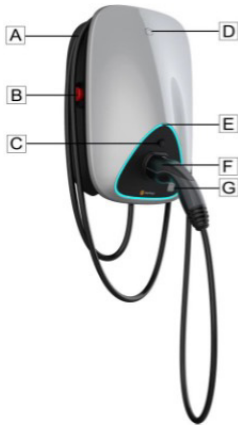

Figure 3-3 Appearance of the wall-mounted (Subject to the actual product)

- [A]——Cable winding trough
- [B]——Emergency stop: press the button to stop the device when it is running abnormally
- [C]——Charge connector unlock button
- [D]——RFID card reader
- [E]——LED status indicator
- [F]——Position of the charging connector and cable winding bracket
- [G]——Authenticate to start by scanning QR code



- The appearance is subject to the actual product.
- When charger is not in use, the charging cable should be rolled up and placed back on the stand, and the charging connector should be inserted into the designated position for safe storage.

- Floor-standing charger

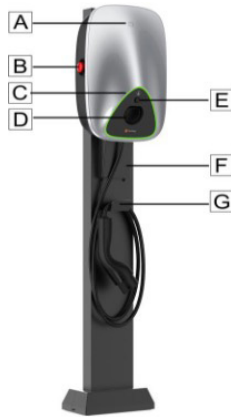

Figure 3-4 Appearance of the floor-standing (Subject to the actual product)

- [A]——RFID card reader
- [B]——Emergency stop: press the button to stop the device when it is running abnormally
- [C]——LED status indicator
- [D]——Charger plug position
- [E]——Position of the charging connector
- [F]——Mounting Column
- [G]——Cable winding bracket



- The appearance is subject to the actual product.
- When charger is not in use, the charging cable should be rolled up and placed back on the stand, and the charging connector should be inserted into the designated position for safe storage.

## 3.2 Start-up charger

### PRECONDITION

- The charging connector is not inserted in the vehicle.
- The charger is ready for operation (the LED status is green).

### THE STEPS

#### DOMESTIC- PLUG&PLAY:

**Step 1** Insert the charging connector into the vehicle and confirm that it is connected properly, when the green LED light changes to Blue, it means the charger is connected with the EV.

**Step 2** When the blue LED is pulsing, the charging process starts.

#### DOMESTIC- RFID ENABLE:

**Step 1** Insert the charging connector into the vehicle and confirm that it is connected properly, when the green LED light changes to Blue, it means the charger is connected with the EV.

**Step 2** Tap the RFID card to the card reading area until the LED indicator flashes.

**Step 3** When the blue LED is pulsing, the charging process starts. If tapping the RFID card fail to start charging, please star over again.

#### COMMERCIAL - OCPP ENABLE:

**Step 1** Insert the charging connector into the vehicle and confirm that it is connected properly, when the green LED light changes to Blue, it means the charger is connected with the EV.

**Step 2** Use OCPP platform to scan the QR code for charging.

**Step 3** When the blue LED is pulsing, the charging process starts.

## 3.3 End Charging

### THE STEPS

**Step 1** After tapping card to stop charging, unplug the connector from the vehicle to end the whole charging process.

**Step 2** Put the cable back on the bracket provided with the charger.



## 3.4 Indicator Description

CHARGER LED EXPLANATION			
NO.	CHARGER STATUS	LED INDICATOR COLOR	LED EFFECT
1	Standby	Green	Constant
2	Charging	Blue	Changes gradually
3	Fault	Red	Constant
4	Charging stopped by Vehicle	Blue	Pulsate (1 second)
5	Connected but not charging	Blue	Constant

# 4. Troubleshooting

FAULT	POSSIBLE CAUSES AND SOLUTIONS
POWER LED IS OFF	<ul style="list-style-type: none"> <li>No power supply               <ul style="list-style-type: none"> <li>Check there is power going to the unit and that the isolator switch is on.</li> <li>Check that the emergency button on the side of the charger is not pressed in. Reset it if it is.</li> </ul> </li> <li>LED light still off               <ul style="list-style-type: none"> <li>Please contact MG.</li> </ul> </li> </ul>
UNABLE TO START THE CHARGING PROCESS	<ul style="list-style-type: none"> <li>Software crash               <ul style="list-style-type: none"> <li>Reboot the charger by cutting off the power supply and switching it back on</li> </ul> </li> <li>Working in RFID enable mode               <ul style="list-style-type: none"> <li>Change setting in Web Configuration or use RFID card to start charging</li> </ul> </li> <li>Did not insert the connector into the vehicle properly:               <ul style="list-style-type: none"> <li>Pull out and plug in again.</li> </ul> </li> <li>Did not execute charging steps correctly:               <ul style="list-style-type: none"> <li>Follow the instructions in the 3.1.2 Start-up charger process section.</li> </ul> </li> <li>The connector is dirty or damaged.               <ul style="list-style-type: none"> <li>Clean or replace the charging connector.</li> </ul> </li> </ul>
THE VEHICLE IS NOT FULLY CHARGED OR THE CHARGING TIME INCREASED	<ul style="list-style-type: none"> <li>Due to extreme high temperature of the vehicle or the integrated charger the current drops:               <ul style="list-style-type: none"> <li>Visually check if the plug device is unclean worn or damaged.</li> <li>If necessary, please contact MG.</li> </ul> </li> <li>Due to the external control device (power supply equipment, PV equipment, or others), the charging cannot be completed.</li> </ul>
FAULT STATUS: RED LED LIGHTS ON	<ul style="list-style-type: none"> <li>Fault               <ul style="list-style-type: none"> <li>Check all possible cause for failure in the first place (*), eg the emergency stop button is pressed accidentally</li> <li>Make sure that the emergency stop button is pressed to keep safe.</li> <li>Turn off the power supply of the charger, pull out the charging connector of the vehicle and switch the power supply back on.</li> </ul> </li> <li>Damage               <ul style="list-style-type: none"> <li>Please contact your service partners.</li> </ul> </li> </ul>

**(\*) Possible causes for failure (fault status, red LED light on):**

- In principle, the fault should be solved by pulling the charging connector out of the vehicle
- When the emergency stop button is pressed, the LED light will turn red. Reset the emergency stop button by twisting it
- If the error code shows Ungrounded, leaked, or no charger ID, please contact MG to maintain the ChargeHub.

# 5. Routine Maintenance

The following routine maintenance items are for reference only. Please refer to the relevant standards and operation instructions for operation.

## 5.1 POWER DISTRIBUTION SYSTEM

Power on and off steps of the distribution box.

1. Check if the supply voltage is normal.
2. Power on: first turn on the main switch of the distribution box and then the branch circuit switch.
3. Power off: first turn off the branch circuit switch, and then turn off the main switch of the distribution box.

## 5.2 WIRING SYSTEM

### 5.2.1 CABLE

- Weekly routine inspection: check cable for heating and breakage.
- Monthly routine inspection: check cable for heating, breakage, whether the cable is subjected to external pull force, Fixed securely.
- Annual routine inspection: check whether the cable is connected closely to the switch, whether the grounding is reliable, whether the cable is hot or damaged, and whether the insulation resistance of the cable is in accordance with the regulations. The sealing measures of cable into the box are intact, hole sealing is tight.

## 5.3 CIRCUIT COMPONENTS

### 5.3.1 COMPONENTS

- Weekly routine inspection: check if the emergency stop button is working normally. After pressing the emergency stop button and that it is confirmed the control circuit is disconnected, check whether all operation indicator lights and buzzers are working normally and if the charging connector's fixed clasp is damaged or the connection is abnormal.
- Quarterly routine inspection: check whether the circuit components are fixed firmly and if there is a phenomenon of fire burning at the connection of the components. If any abnormality is found, please replace the components as fast as possible.
- Annual routine inspection: use a brush and vacuum cleaner to remove the dust from the box. When cleaning, be careful to not blow dust into the components because it will cause a short circuit.

Complete inspection of all components and parts of the box. If any abnormality is found, please replace the parts as fast as possible.

## **5.4 AUXILIARY SYSTEM**

### **5.4.1 INDICATOR LIGHTS**

- Monthly routine inspection: check if the LED indicator is fixed firmly.
- Annual inspection: make sure the wire and indicator light connections are tightly sealed and do not have corrosion and that all the accessories of the indicator lights are completed, fixed firmly and have not burned out. Also check if the incoming insulation is in compliance with the regulations.

## **5.5 ELECTRICAL GROUND SYSTEM**

Electrical grounding is very important in electrical safety. The safety of human and equipment depends largely on the integrity and safety of grounding equipment. If the grounding equipment is not solid, reliable and does not comply with local standards, it will create risks for human lives and the equipment itself.

Therefore, careful inspection and timely maintenance must be carried out to keep the ground system in a good condition.

- Weekly routine inspection: check if the grounding of the equipment is loose, lost or altered. Observe carefully whether the grounding of the equipment is intact and if the anti-loosening device is completed, damaged or removed.
- Monthly routine inspection: make sure whether the connection of electrical grounding system is rusty, with oxidation or unstable; if it does, it will increase earth resistance. Also check if the grounding mark is completed or damaged. Check the device in the switch box for looseness, corrosion, and rust.
- Annual routine inspection: make sure the grounding wires and terminals are in good condition. Use the multi-meter to detect whether the grounding resistance meets or exceeds the standard grounding requirements.

## **5.6 APPEARANCE**

Monthly routine inspection: check if there is corrosion or damage on the appearance, do regular cleaning for the device.

## 5.7 Maintenance Period

INSPECTION ITEM	EVERY MONTH	EVERY QUARTER	EVERY HALF YEAR	ANNUAL	METHOD
Charging connector	✓	✓	✓	✓	Check
Leakage switch protection	✓	✓	✓	✓	Check
Emergency stop function check	✓	✓	✓	✓	Test
Dust inspection of control board	✓	✓	✓	✓	Check and Clear



# 6. Customer Service

## 6.1 PREPARATION

If you have any questions or problems, please contact the company responsible for performing the electrical installation.

Before contacting Customer Service:

- Check the troubleshooting measures in the Troubleshooting section of this manual.
- Check the troubleshooting measures in the Vehicle Manufacturer's manual.
- Record the model and serial number of the device

## 6.2 CONTACT INFORMATION

**Company address:** MG Motor Australia & New Zealand

(Level 19, 100 Arthur Street, North Sydney NSW 2060)

**Website:** [mgmotor.com.au](http://mgmotor.com.au) & [mgmotor.co.nz](http://mgmotor.co.nz)

**Company E-mail:** [anz.evsupport@smil.com](mailto:anz.evsupport@smil.com)

**Hotlines:** 1800 642 277 (in Australia)

# A. Installation Instruction

## A.1 INSTALLATION REQUIREMENTS

- The charger should not be installed close to dangerous locations such as water pipes, gas pipes, and steam pipes.
- The installation location should be convenient for charging. When laying the circuit, the wiring length should be shortened, and the cable resistance energy consumption should be reduced.
- The installation location should not be submerged in water when it rains. The installation should be vertical and the center of gravity should not be too high to prevent tipping or tilting. It should not be placed in a place with severe vibration or high temperature. The height of the charging column should be about 60cm from the horizontal plane.
- The wall-mounted charger must be connected to the wall at least two points. The wall should be installed to withstand the weight of the charger and its accessories and should not be tilted after installation. The wall and internal lines should not be too close.
- The indoor installation protection level is at least IP32, and the outdoor is at least IP54. It is recommended that the charger be installed in an environment with a sunshade or umbrella; the lighting and passage of the charger installation site must be guaranteed.
- A certain space should be reserved for the installation of the charger, so that the engineering personnel can open the back door of the equipment for inspection and maintenance. Ensure that the ground wire is securely connected to the ground wire of the power supply system.
- It is recommended that customers install 1\*Circuit Breaker + 1\*RCD or an RCBO in front of the EV Charger. The Circuit Breaker and RCD needs to meet local regulations. The recommended specifications of the circuit breaker are as follows.

### CIRCUIT BREAKER

POWER	SERIES	RATED VOLTAGE	RATED CURRENT	TRIPPING CURVE CODE
7kW	IP+N	220V	40A	C
11kW	3P+N	400V	20A	C

### RESIDUAL CURRENT DEVICE

POWER	SERIES	RATED VOLTAGE	RATED CURRENT	EARTH-LEAKAGE SENSITIVITY	EARTH-LEAKAGE PROTECTION CLASS
7kW	IP+N	220V	40A	30 mA	Type A
11kW	3P+N	400V	20A	30 mA	Type A

# A.2 Power Supply Requirements

The power supply mode of the 7kW AC charger is AC single-phase power supply, and the input electrical requirements are shown as follow:

- AC working voltage: AC 230V
- AC working frequency: 45Hz~65Hz
- Voltage asymmetry: no more than 5%
- Voltage distortion rate: 10% of non-sinusoidal content does not exceed 10% of 230V

The power supply mode of the 11kW AC charger is AC three-phase power supply, and the input electrical requirements are showed as follow:

- AC working voltage: AC 400V
- AC working frequency: 45Hz~65Hz
- Voltage asymmetry: no more than 5%
- Voltage distortion rate: 10% of non-sinusoidal content does not exceed 10% of 400V

## A.3 ENVIRONMENTAL REQUIREMENTS

- Working environmental temperature: -30°C~+50°C
- Relative humidity: 5% to 95%
- Installation vertical tendency: ≤5%
- Installation and operation altitude: ≤ 2000 meters
- There is no strong vibration and impact at the place of use, and there is no strong electromagnetic interference.

## A.4 WIRING REQUIREMENTS

- Recommended cable specifications of 7kW charger :6mm<sup>2</sup> ( (brown L1, blue N, green yellow PE), outside diameter 13 mm-15 mm;
- Recommended cable specifications of 11kW charger:6mm<sup>2</sup> (brown L1, black L2, grey L3, blue N, green yellow PE).
- **Important Note:** Recommendations are based on cable run within 40 meters. For longer cable runs please refer to local regulations. Eg. AS/NZS 3000)

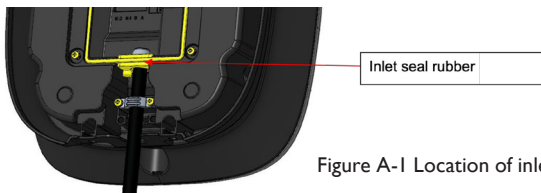

Figure A-1 Location of inlet seal rubber

Conductive core maximum allowable operating temperature: 105°C

Ambient temperature: 0°C and above

# A.5 Product Installation

- Tool list

Electric drill, tape measure, screwdriver, pen, tape, tool hammer, mounting screws, expansion screws, hex wrenches, crimping tools, paper-knife.



## A.5.1 WALL-MOUNTED CHARGER

The general assembly drawing is shown in Figure A-2.

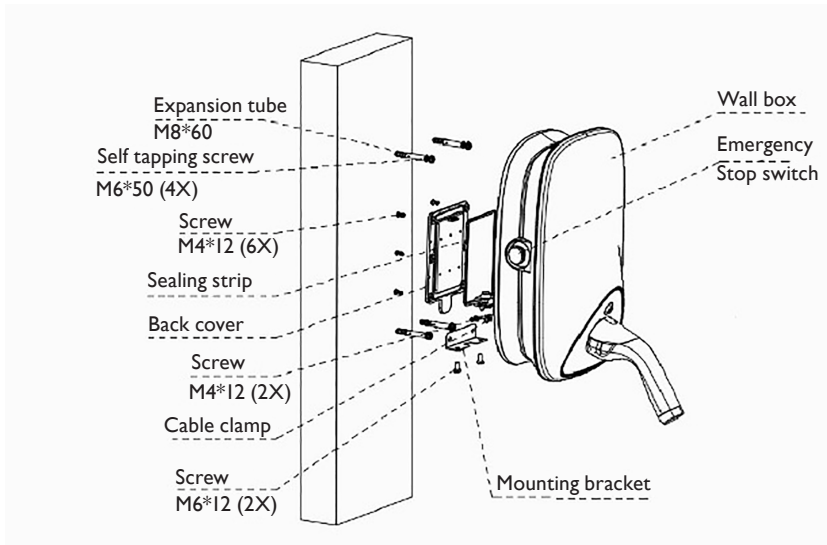

Figure A-2 General assembly drawing of wall-mounted charger



- I. Please confirm the installation location and mark it on the wall. It is suggested that the top height of charger should be about 1.2 meters from the ground, as shown in Figure A-3.

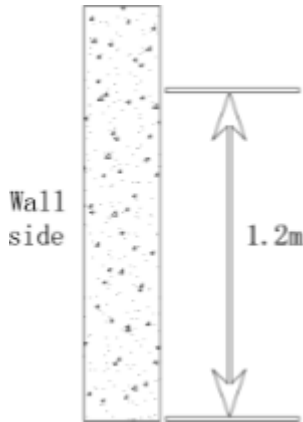

Figure A-3 Wall mounting height

2. As shown in Figure A-4, the center distance of the wall drilling hole, place the drilling template at a suitable height, and mark the punching position on the wall with a pencil.

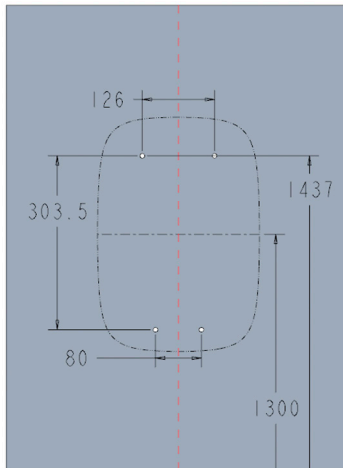

Figure A-3 Drilling template

3. Use a  $\Phi 8$  drill bit for the wall to open 4 holes with a depth of 70mm, install an  $\Phi 8^*60$  expansion tube, and use two M6 self-tapping screws to fasten the wall mount to the two holes under the wall, and directly tighten the two holes on the top. Insert two M6 self-tapping screws. Note that the screw head protruding height is 7mm, as shown in Figure A-5.

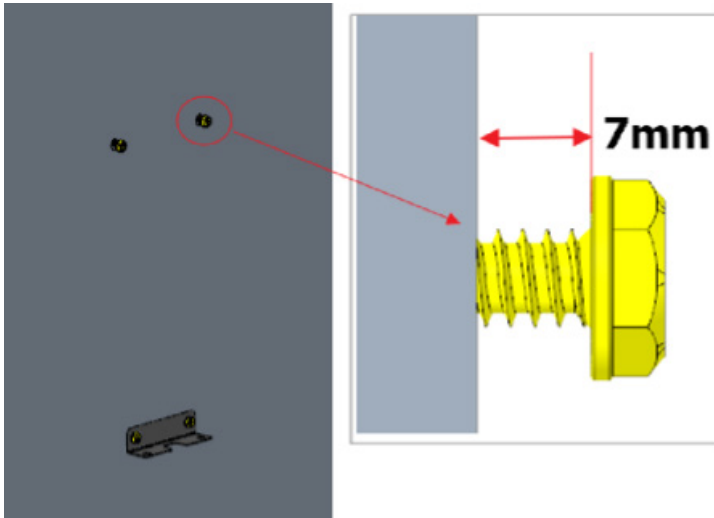

Figure A-5 Fixed Socket and Socket holder bracket

4. Thread the incoming cable through the large hole in the center of the rubber plug of the cable, compress the terminal, and fasten it to the wiring connector with a screw (torque 1.8 Nm, there is a wiring comparison table in the shell).
5. (Optional) If you need to install a network cable (depending on the configuration), you need to cut through the channel on the left side of the cable, insert the network cable, and plug it into the corresponding interface.
6. (Optional) If you need to install a SIM card (depending on the configuration), insert the SIM card directly into the corresponding connector.
7. (Optional) If an external shunt trip is required, the two connecting points reserved according to the indicated position of the product shall successively connect the shunt trip control circuit with a voltage not higher than 230Vac and a current not exceeding 1A in the control circuit, as shown in the following figure:

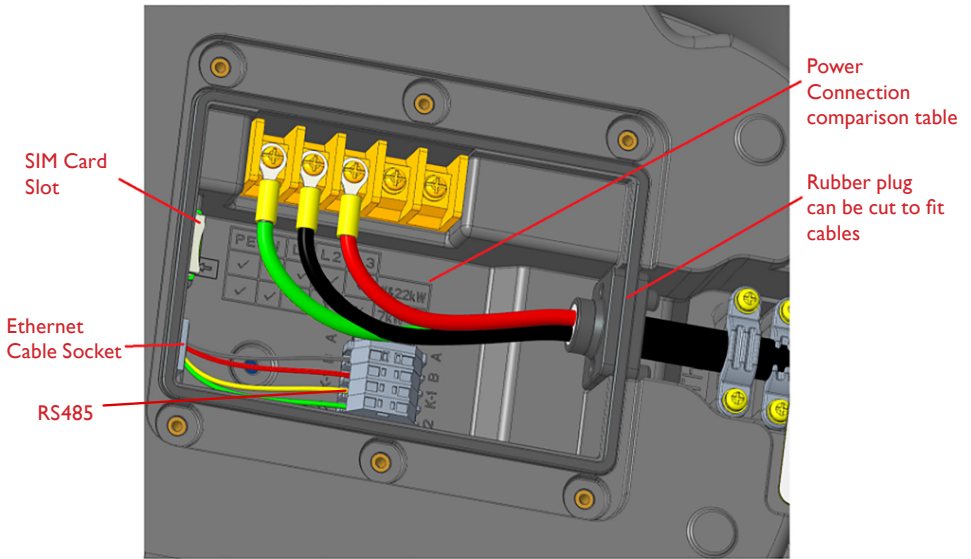

Figure A-6 7kW wiring diagram

8. The 11kW charger is connected with 5 entry cables, as shown in Figure A-7 below.

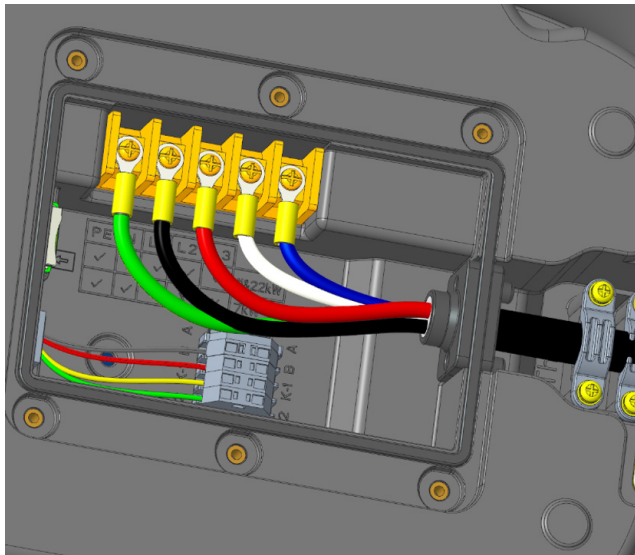

Figure A-7 11kW wiring diagram

9. Use 6 M4\*12 screws to tighten the wiring compartment cover, and 2 M4\*12 screws to tighten the crimping ferrule. Note that there are two positions for the crimping ferrule, depending on the thickness of the incoming cable, as shown below A-8.

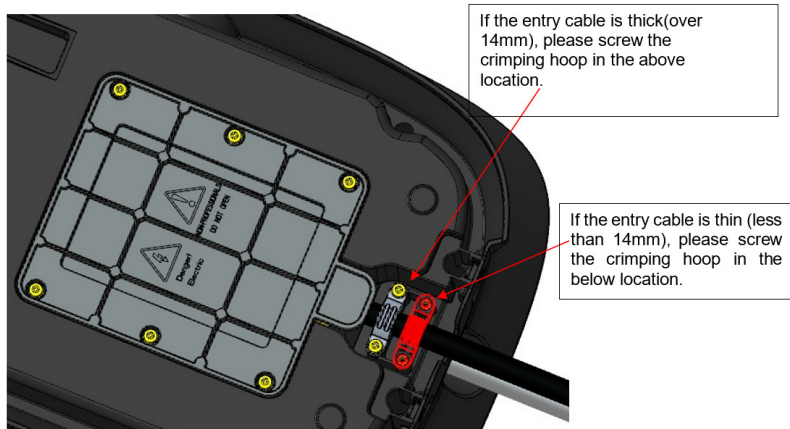

Figure A-8 Install the wiring cover and the cable entry clamp

10. Hang the charger through the two recessed buckles in the rear case and the two screws on the wall, screw in the two M6\*12 Torx screws below to tighten the charger and the wall hanging fitting, as shown in Figure A-9 As shown:

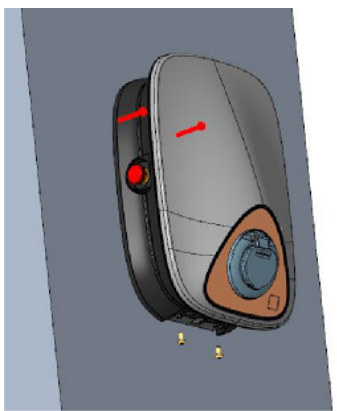

Figure A-9 Hanging charger and bottom fastening

- Check after installation
- I. Clean up
  - Dispose of all shipping and packaging materials in accordance with local regulations.
  - Clean the charger and surrounding debris, such as small cables, straps, screws/mothers, etc. Do not leave the installation tools on site or in the charger (record the type and quantity of tools to prevent omission).
  - Wipe the insulation with an antistatic cloth. Do not use any corrosive solvents.



## 2. Inspection

- Check that the base is secure and sealed.
- Check that the internal components of the device are securely fastened.
- Check that the electrical connections and wiring are correct and complete, that the connections are secure, and that the grounding is reliable.
- Check that the degree of protection of the equipment meets the requirements, especially at the cable entry at the bottom of the charger.
- View appearance, marking, integrity, cleanliness.

### A.5.2 FLOOR STANDING CHARGER

The general assembly drawing is shown in Figure A-10.



Figure A-10 Floor standing assembly drawing

- Install incoming line and charger
1. Lay the column flat on the ground and pass the incoming line out from the front.

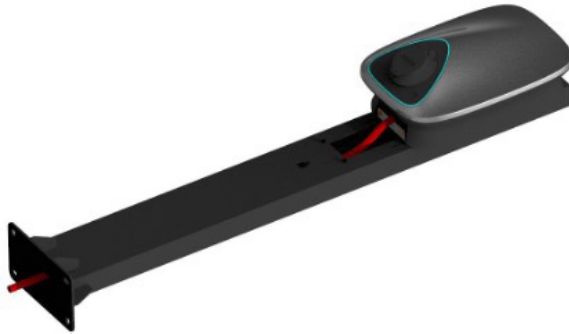

Figure A A-11 Into the line installation

2. After connecting the inlet line with the charger body, fix the charger body on the vertical column. First, use 2 cross M6\*12 (torque: 1.8-2.0n.m) combination screws to fix the wall mount on the column.
3. Hang the charger on the column, screw in two pattern M6\*12 (torque: 1.8~2.0 N.M) combination screws at the bottom, as shown in Figure A-12.



Figure A-12 Charger installation

4. Insert the hanger hook and guard cover into the mounting position and push them up, and then lock them from the front with two M4\*12 pattern composite screws (Torque: 1.4~1.6 N.M) with column core head, as shown in Figure A-13.

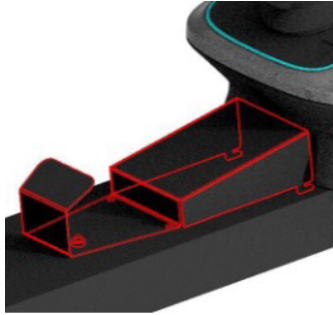

Figure A -13 Thread hook and thread guard installation

- Fixed base

1. Drill 4 holes with A diameter of 10mm and A depth of 150mm on the concrete floor, and the spacing between hole centers is 100mm\*200mm. Use 4 M10\*120 expansion screws to install and tighten the charger posts, as shown in Figure A-14 and A-15.

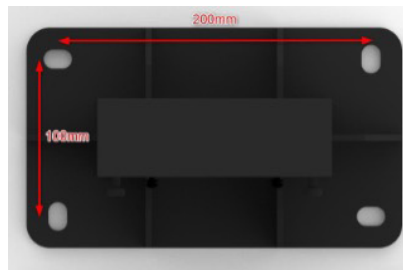

Figure A-14 Fixed base



Figure A-15 Fixed column

2. Place the rear decorative cover on the bottom plate of the column.

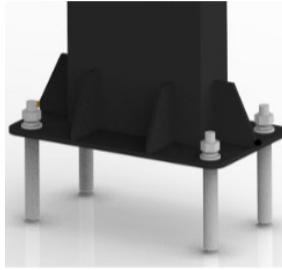

Figure A-16 Install the rear decorative cover

3. Insert the front decorative cover into place from top to bottom and the back decorative cover, and fix both sides of the front decorative cover with 2 M4\*12 flower-shaped composite screws (Torque: 1.4~1.6 N.M) with column core.



Figure A-18 Fixed the decorative cover

- Check after installation
1. Clean up
    - Dispose of all shipping and packaging materials in accordance with local regulations.
    - Clean the charger and surrounding debris, such as small cables, straps, screws/mothers, etc. Do not leave the installation tools on site or in the charger (record the type and quantity of tools to prevent omission).
    - Wipe the insulation with an antistatic cloth. Do not use any corrosive solvents.
  2. Inspection
    - Check that the base is secure and sealed.
    - Check that the internal components of the device are securely fastened.
    - Check that the electrical connections and wiring are correct and complete, that the connections are secure, and that the grounding is reliable.
    - Check that the degree of protection of the equipment meets the requirements, especially at the cable entry at the bottom of the charger.
    - View appearance, marking, integrity, cleanliness.

## B. Web Configuration Instruction

- These instructions are for the Web Configuration of MG ChargeHub, including basic settings for domestic users such as changing charging mode, connecting to the Internet, and advanced setting such as OCPP for commercial users.
- During the configuration, the “Submit” button is used to upload the configuration to the charger, and the “Refresh” button is to refresh and check the existing configuration setting from the ChargeHub. You can use the “refresh” button to view the charging point configuration and confirm whether the configuration has been uploaded successfully. Every time you submit or refresh, the browser will send you a notification if the action was successful.
- Please note that before you change any setting on Web Configuration, you need to disconnect the charger from the EV, then check if the LED of ChargeHub is GREEN. Otherwise, your charger might not be installed correctly, please contact MG for help.

### CHARGER LED EXPLANATION

NO.	Charger Status	LED indicator color	LED Effect
1	Standby	Green	Constant
2	Charging	Blue	Changes gradually
3	Fault	Red	Constant
4	Charging stopped by Vehicle	Blue	Pulsate (1 second)
5	Connected but not charging	Blue	Constant

- The table above explains the meaning of different LED effects of ChargeHub.

# B.1 Login into web configuration

## B.1.1 Via WiFi

(Configuration via WiFi is available for smartphones and laptops)

- a) After correct installation, the MG ChargeHub will broadcast a WiFi hotspot. Please stand within 5 meters of the Charger. Then search for the below WiFi network:

Hotspot name(SSID)	MG_ChargeHub
Password	Wb123456789

- b) If the charger is not broadcasting a network, please ensure it is turned on and operational with a GREEN or BLUE light on the front.
- c) Once connected, visit “http://192.168.1.136” on your internet browser. If successful it will display an MG login page where it asks for login details. Input the following details.

User Name	xxcd
Password	28912891

Finally, click “Sign me in”. You should now have access to the configuration pages.

Note: It should be noted that some devices will give priority to using mobile data rather than WiFi when the WiFi has limited Internet access (while we are configuring, the ChargeHub WiFi has limited access to the Internet). If you can't access the Web Configuration page, please turn off your mobile data and try again.

## B.1.2 Via Ethernet cable

- a) First, please confirm that your charger has been installed correctly, when the charger is showing a GREEN/BLUE light, it means the charger is connected correctly, you may proceed to step (b). If the charger is showing a RED light, contact your installer or MG to fix it.
- b) One end of the Ethernet cable should be connected directly into the charger. The other end should be connected to a laptop or other device to allow access.
- c) Once you've connected the cable. Change the network access type to “Ethernet” in your computer settings (Usually found in **network and internet settings** of the **control panel**)

d) Click the “Ethernet” button.

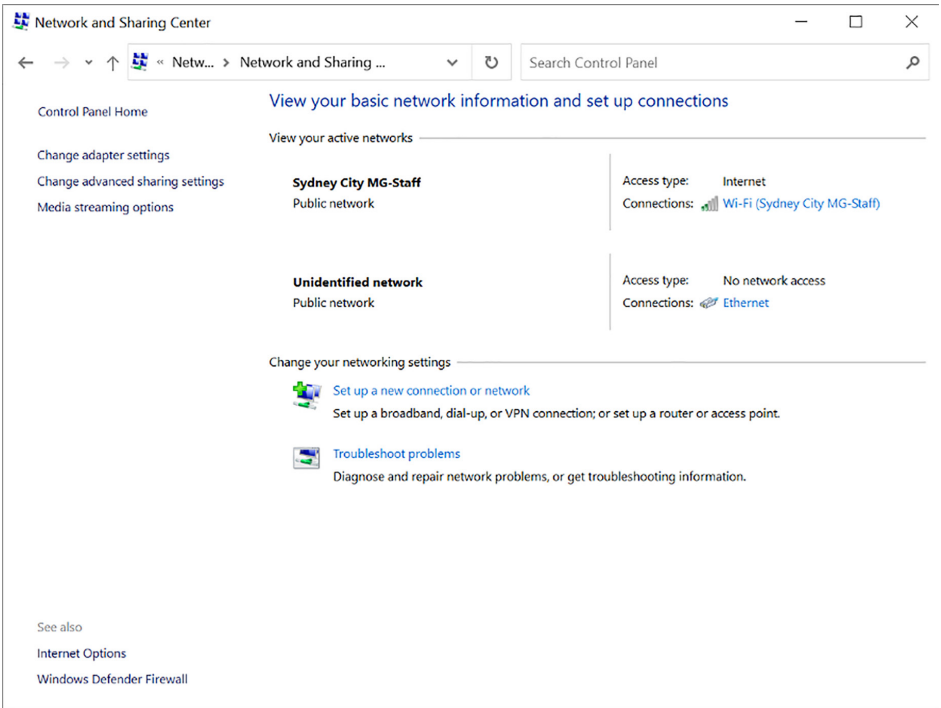

e) Click “Properties”

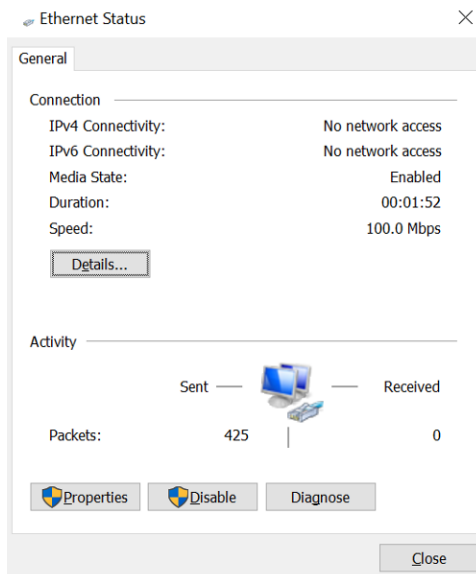

f) Click " Internet Protocol Version 4 (TCP/IPv4)"

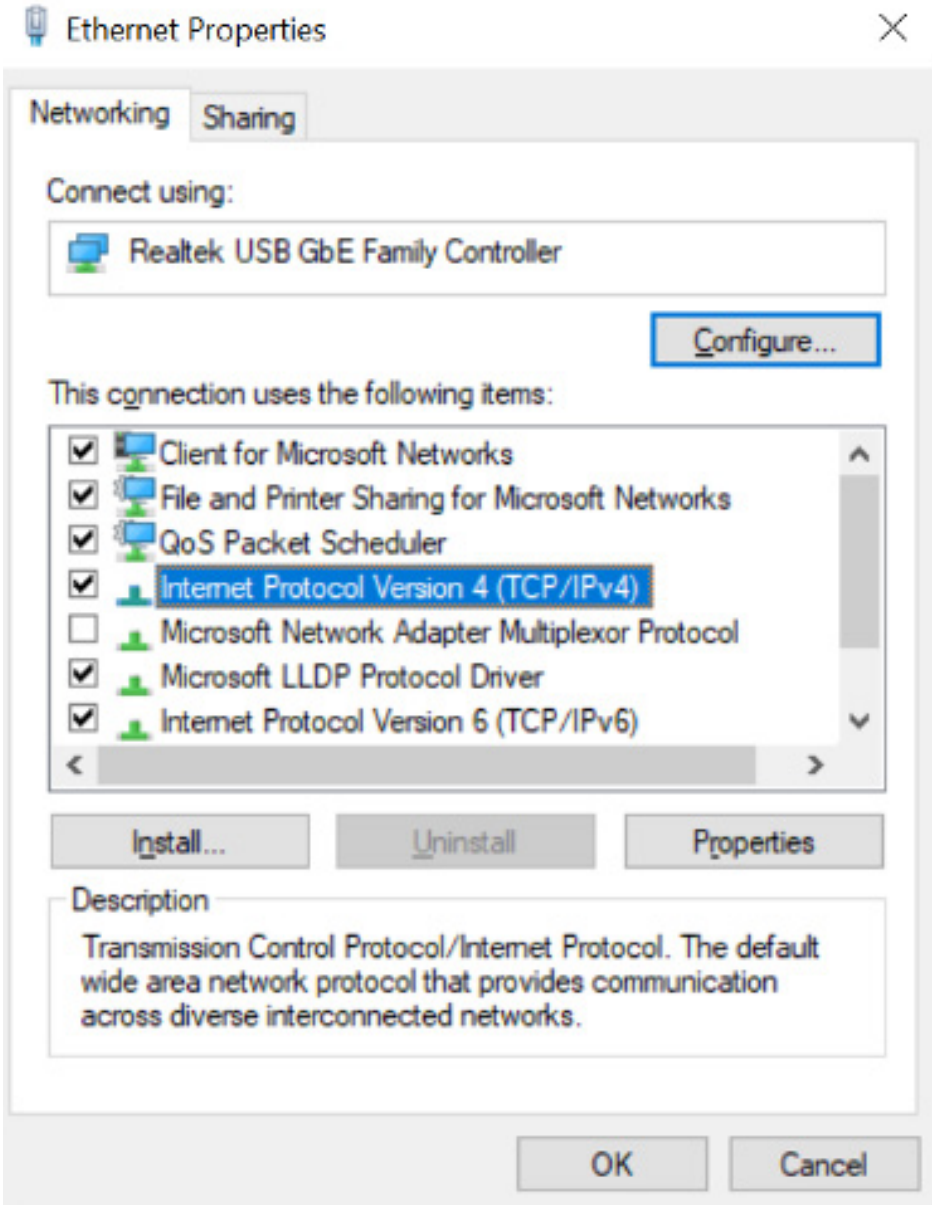



- g) Set the IP address and Subnet mask as below. The rest of the settings do not need to be changed. Click OK or Save.

IP address	192.168.88.9
Subnet mask	255.255.255.0

## Internet Protocol Version 4 (TCP/IPv4) Properties



**General**

You can get IP settings assigned automatically if your network supports this capability. Otherwise, you need to ask your network administrator for the appropriate IP settings.

Obtain an IP address automatically

Use the following IP address:

IP address:

Subnet mask:

Default gateway:

Obtain DNS server address automatically

Use the following DNS server addresses:

Preferred DNS server:

Alternate DNS server:

Validate settings upon exit

- h) Open an internet browser and visit 'http://192.168.88.206'. If successful it will display an MG login page where it asks for login details.

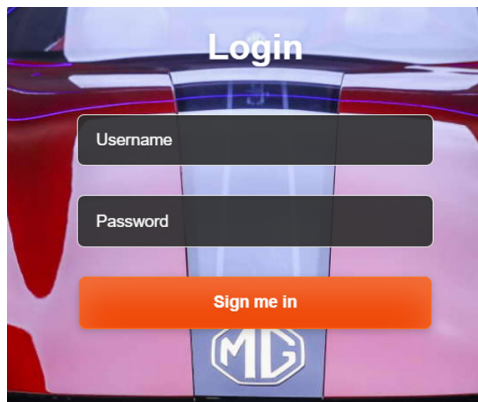

- i) The login details are:

User name	xxcd
Password	28912891

- j) If you cannot access the web page, it should either be because the IP address in the previous step is not set correctly or the network cable is not plugged in properly. Please check both steps. If it still doesn't work, contact MG for help.

## B.1.3 Via Ethernet cable method 2

If the methods in 1.2 don't work, please try the method below:

- a) First, please refer to the product instructions to correctly connect the power supply.
- b) Once you've connected the charger with your laptop with a cable, wait for 1 min, click the Network icon in the bottom right corner of your Windows desktop, and then click the "Unidentified Network". (The name might be varied due to different laptops, but there should be only one Ethernet network shown. If there is nothing shown here, click "Network & Internet Settings", the "Ethernet" should be shown there)

- c) Find the “IP settings”, click “edit”.

← Settings

## Unidentified network

### Metered connection

If you have a limited data plan and want more control over data usage, make this connection a metered network. Some apps might work differently to reduce data usage when you're connected to this network.

Set as metered connection

Off

If you set a data limit, Windows will set the metered connection setting for you to help you stay under your limit.

[Set a data limit to help control data usage on this network](#)

### IP settings

IP assignment: Automatic (DHCP)

Edit

- d) Change the IP Settings to manual.

### Edit IP settings

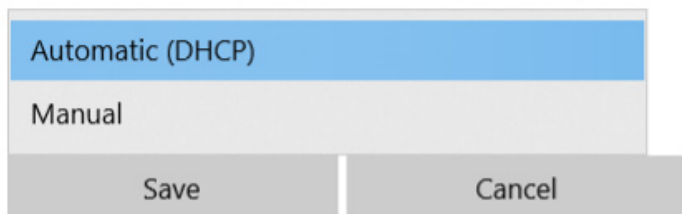

e) Set

## Edit IP settings

Manual 

### IPv4

On

IP address

192.168.88.6

Subnet prefix length

24

Gateway

192.168.88.206

Preferred DNS

Alternate DNS

### IPv6

Off

Save

Cancel

---

IP address:	192.168.88.6
-------------	--------------

---

Subnet Prefix Length:	24
-----------------------	----

---

Gateway:	192.168.88.206
----------	----------------

---

- f) Open an internet browser and visit 'http://192.168.88.206'.
- g) After launching, put in user name and password.

User Name	xxcd
Password	28912891

- h) If you cannot access the web page, please check if the IP is correct and check if the Ethernet cable is connected correctly. If everything is correct but you still can't get access to the Web page, contact MG for help.

## B.2 Setting charging mode

There are 3 charging modes for ChargeHub:

- **Plug and Play/Local PnC (Plug and Charge):** This mode is suitable for most domestic scenarios and is the default mode. It can be described as Plug&Play, anyone can charge their vehicle via the charger by simply plugging it in. When operating in "Local PnC", the smart features such as OCPP Platform connectivity will not be activated.
- **Start and Stop Card:** Also called RFID Card. When switched to this mode. The charger will only start or stop charging when the associated RFID Card is tapped at the card reader. The OCPP platform can also be used to start or stop the charger in this mode.
- **Billing Card:** The OCPP platform is the only method to start or stop the charger in this mode.

## B.2.1 Plug and Play (default mode)

The screenshot shows the MG Motor web configuration interface. On the left is a dark sidebar with navigation options: Quick Setup, Hardware Setting, Software Setting (highlighted in orange), Charging Status, and Upload and download. The top header contains the MG Motor logo, the text 'MG Motor', and user settings for 'Language' and 'User Set'. The main content area is titled 'Functions Enable' and contains four dropdown menus: 'Card Type' (set to 'Local PnC'), 'Local startup whether to go ocpp background' (set to 'No'), 'Whether to open the qr code process' (set to 'No'), and 'Whether to transfer private data' (set to 'No'). At the bottom right of the form are 'Submit' and 'Refresh' buttons.

- a) Click “Software Setting”, Then find “Functions Enable” on the right.
- b) For the Card Type, select “Local PnC”. Then click” Submit”.
- c) Wait for at least 5 mins, the system feedback will show “submit successfully”.
- d) Click “Refresh” to see if the setting has been uploaded correctly.
- e) Then, disconnect from the web configuration and restart the charger (turn it off then turn it on, using the isolator switch near the charger).
- f) The charger should be set to “Plug&Play” (Local PnC) now.

## B.2.2 Enable by RFID Card

The screenshot shows the MG Motor software interface. At the top left is the MG Motor logo. On the right, there are links for "Language" and "User S". A left sidebar contains navigation options: "Quick Setup", "Hardware Setting", "Software Setting" (highlighted in orange), "Charging Status", and "Upload and download". The main content area is titled "Functions Enable" and contains four dropdown menus and two buttons. The "Card Type" dropdown is set to "Start stop card". The "Local startup whether to go ocpp background" dropdown is set to "No". The "Whether to open the qr code process" dropdown is set to "No". The "Whether to transfer private data" dropdown is set to "No". There are "Submit" and "Refresh" buttons to the right of the dropdowns.

- Click "Software Setting" then find "Functions Enable".
- For the Card Type, select "Start stop card". Then click "Submit".
- Wait for 30 seconds, the system feedback will show "submit successfully".
- Click "Refresh" to double check if the setting has been uploaded correctly.
- Then, restart the charger (turn it off then turn it on).
- The charger should be enabled by RFID Cards now.

To test the RFID Card: Firstly, connect the charger with your EV. Then tap the RFID Card on the RFID sensor (directly above the MG logo on the front near the top). The charger LEDs should change to indicate if the car is charging if it is plugged in.

## B.3 Connect to the Internet

- a) ChargeHub comes with smart features, it includes smart charging, electricity bill record, charging data monitoring and record etc. They are available via OCPP. To activate smart features, the charger needs to be connected to the Internet.
- b) ChargeHub can connect the Internet via SIM(4G), WiFi(2.4G), and ethernet cable.
- c) As shown in the screenshot below, in “Software Setting”-“Network priority selection”. When your charger has multi-method to connect to the Internet, you can decide the priority of methods when connecting to the Internet.
- d) Please note that every time the network connection mode or the network configuration is changed, the charger will reboot and the Internet connection will be re-connected automatically after a few minutes.

### B.3.1 Via SIM card

- a) Ask the installer to insert the SIM card during the installation, the SIM slot is located at the back of ChargeHub. The SIM size is “Standard SIM”.

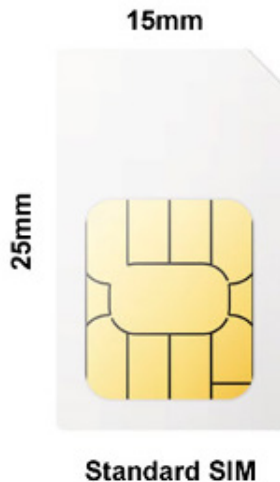



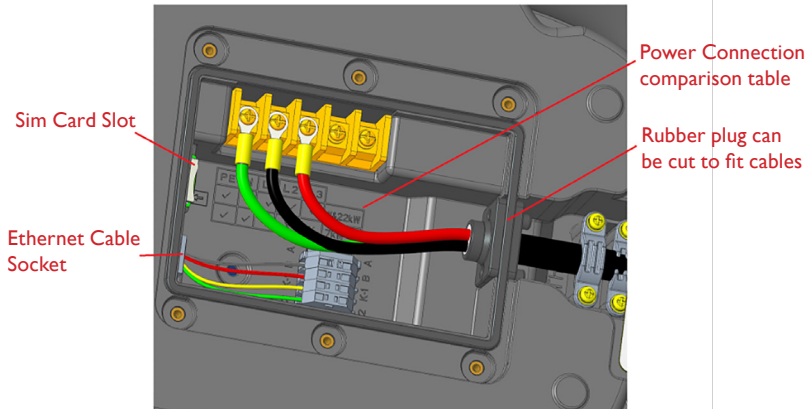

(If you want to insert the SIM card after the installation, please contact an electrician for help. For your safety, please **DO NOT** attempt to do this unless you are a qualified electrician).

- b) After entering the web page and setting your networking priorities, check the 4G signal and connection status according to “Status Check”.
- c) If the 4G signal is too weak, check if the SIM Card is inserted correctly and activated correctly. Then restart the device and repeat the preceding procedure.
- a) When not using Telstra network, APN (Access Point Name) must be set. The APN can be obtained from the local network provider. The following guide shows how to set APN.
  - i. Click “Software Setting”.
  - ii. Choose “Enable modification” in “4G configuration”.
  - iii. Fill in correct APN data.
  - iv. Click “Submit”.

Note: APN for Telstra SIM Card is “telstra.wap”. For other SIM card suppliers, please check with your provider.

## B.3.2 Via WiFi STA

MG ChargeHub has 2 WiFi modes, AP and STA:

1. AP(Access Point) is the default mode. In AP mode, ChargeHub is a source of WiFi, broadcasting a WiFi named “MG\_ChargeHub”. Other devices can access the Web Configuration page via the ChargeHub WiFi. Note: AP mode has no access to the Internet.
2. STA(Wireless Client Station) mode, the charger is connected to the Internet via hotspots such as your local WiFi network, which can access the Internet and exchange data with the OCPP platform.

**Important note: Once STA mode is enabled, you can no longer access the Web Configuration via the WiFi named “MG\_ChargeHub” until you change it back to AP mode by Ethernet cable. However, you can still access the Web Configuration via Ethernet.**

Once you've set your networking priorities correctly, make sure the AP band of the WiFi is 2.4G band. In Australia and NZ, a typical router can broadcast a 2.4G WiFi and a 5G WiFi by default. 2.4G is preferred as it can broadcast over longer distances.

While setting up your Router, WPA2 is the recommended encryption method.

### B.3.2.1 Connecting to local WiFi

- a) Click on “Software Setting”.
- b) Check “WiFi enable”.
- c) Set “Mode selection” to STA.
- d) Fill in the correct SSID (WiFi Name), Psw (Password) and the same encryption method (normally WPA2) as your WiFi connection.
- e) Click “Dhccp enable” (Essential, otherwise it will not have Internet access)

## Wifi configuration

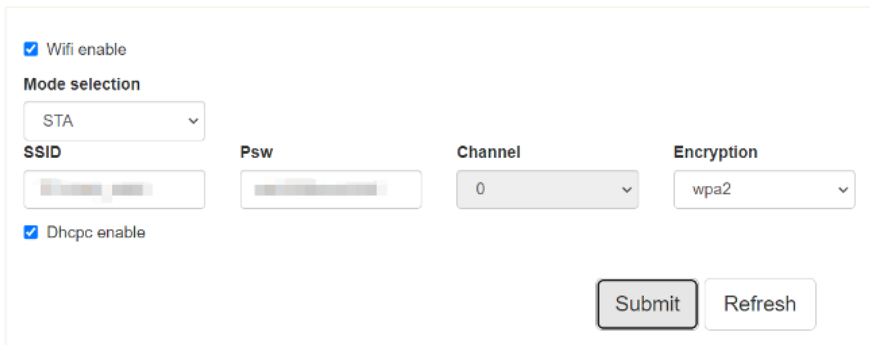

The screenshot shows a web form for WiFi configuration. It includes a checked checkbox for "Wifi enable", a "Mode selection" dropdown menu set to "STA", and a checked checkbox for "Dhccp enable". There are four input fields: "SSID" (with a blurred password), "Psw" (with a blurred password), "Channel" (set to "0"), and "Encryption" (set to "wpa2"). At the bottom right, there are two buttons: "Submit" and "Refresh".

- f) Click “Submit”.

Then refresh the web page to check the connection via “Charging status” - “Status Check”.

Note that once STA mode is enabled, you can no longer access the Web Configuration via the WiFi named “MG\_ChargeHub” until you change it back to AP mode by Ethernet cable.

## B.3.3 Via Ethernet cable

- a) After you have successfully set the priority of networking mode, connect the router and charger with an Ethernet cable and check the network connection status on the “status check” page.
- b) If the network connection fails, refresh the web page or check the network cable connection and restart the charger.

## B.3.4 Check Internet Connection

Click “Charging Status”, If both “Link status” and “Background connection” are online , then the charger is ready for the OCPP platform

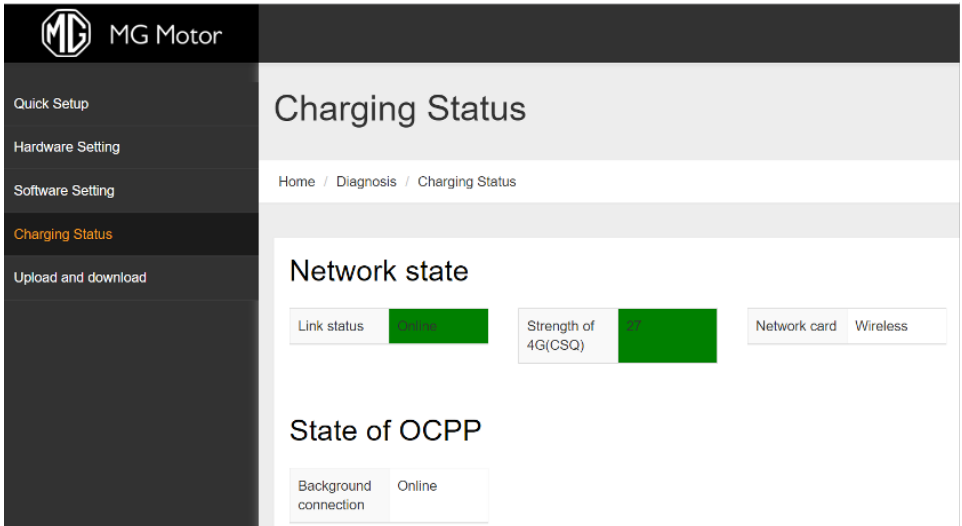

The screenshot shows the MG Motor web interface. The top navigation bar includes the MG Motor logo and a sidebar menu with options: Quick Setup, Hardware Setting, Software Setting, Charging Status (highlighted), and Upload and download. The main content area is titled "Charging Status" and includes a breadcrumb trail: Home / Diagnosis / Charging Status. Under the "Network state" section, there are three status indicators: "Link status" (Online), "Strength of 4G(CSQ)" (100%), and "Network card" (Wireless). Below this, the "State of OCPP" section shows "Background connection" as Online.

Then, please refer to Chapter 2.2 <Enable by RFID Cards>. In your “Functions Enable”, set “start stop card” or “billing card” as your “Card Type” .

Finally, the settings are all finished. The ChargeHub is ready to be managed by OCPP Platform.

# B.4 Connect to OCPP Platform

- OCPP is a communication protocol between charge points and back-end platforms. Charge points and platforms from different manufacturers can talk to each other via OCPP.
- OCPP platform also known as CPO (Charge Point Operator), can manage multiple charge points at the same time, it is widely be used in commercial environments. The functions generally include charging data monitoring, billing customer, remote control, load management, energy bill summary etc.
- MG ChargeHub complies with OCPP 1.6, any platform that complies with OCPP 1.6 can work with MG ChargeHub via the Internet. Before connecting to OCPP platforms, please make sure the ChargeHub is connecting to the Internet. Please refer to <B.3 Connect to Internet> to make ChargeHub online.

### To connect ChargeHub to OCPP platforms:

1. Click “Software Setting”, find “OCPP part”, input the URL, Path, Port and Authorization key as provided by your OCPP platform supplier.
2. Set the SSL\_ON as 1. ( set as 1 means SSL is ON, set as 0 means SSL is OFF)
3. Click “Submit”, wait until the web page says “successful”.
4. Click “Refresh” to check if the data has been uploaded correctly.
5. (Optional) Upload the certificate from the Certificate Import if the OCPP platform requires it, the certificate will be provided by the OCPP platform.
6. (Optional) The ChargePoint ID can be changed if requested by the OCPP platform. Click “Hardware Setting” – Find “ChargePoint ID”, input the ID provided by the OCPP platform and click “Submit”.

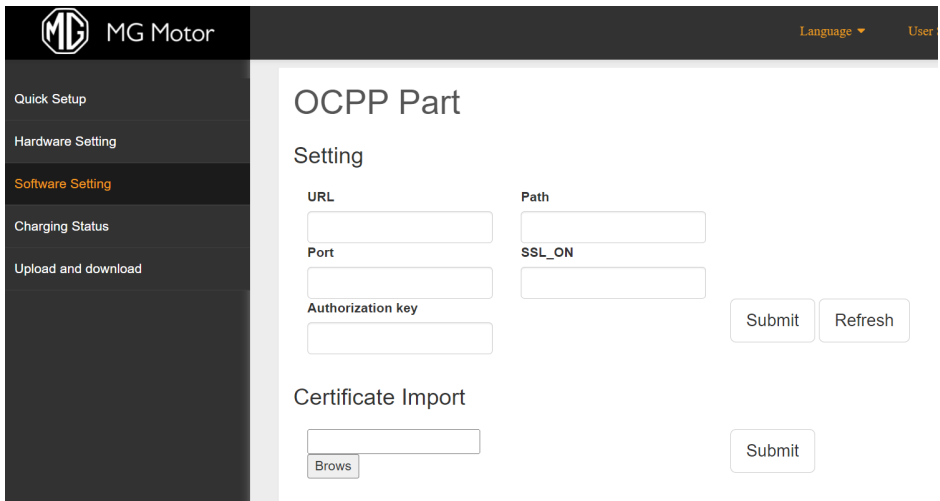

To check the connection between the ChargeHub and the OCPP platform:

1. Click “Charging Status”
2. Check if the “Link Status” and “Background connection” are showing “online”, if they are both online, it means it is all set up from the charger side, check with the OCPP supplier if the App is not working.
3. If the “Link Status” shows “offline”, please refer to “B.3 Connect to the Internet” to set up the Internet connection.
4. If the “Link Status” shows “online” while the “Background connection” shows “offline”. It means the charger is connected to the Internet but it is not connected to the OCPP platform. Please re-check the data input to the “OCPP part” on the previous page or contact your OCPP supplier for support.

The screenshot displays the MG Motor web interface for 'Charging Status'. On the left is a dark sidebar with navigation options: Quick Setup, Hardware Setting, Software Setting, Charging Status (highlighted in orange), and Upload and download. The main content area has a header with the MG Motor logo and the title 'Charging Status'. Below the header is a breadcrumb trail: Home / Diagnosis / Charging Status. The 'Network state' section contains three status boxes: 'Link status' with a green progress bar, 'Strength of 4G(CSQ)' with a green progress bar, and 'Network card' with '4G network' text. The 'State of OCPP' section contains a box for 'Background connection' with the status 'Online'.

# B.5 Restore to Factory Setting

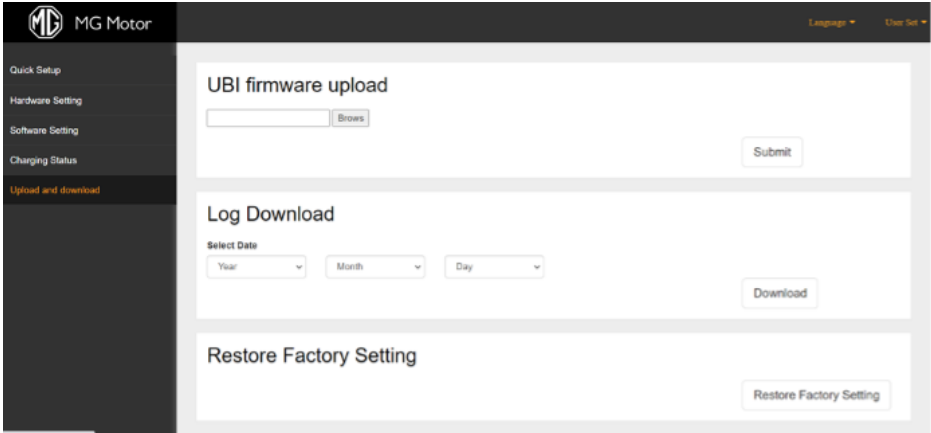

Click “upload and download” – “ Restore Factory Setting”

After the web page shows “success”, wait for at least 10 mins, then re-boot  
( turn the switch/isolator off and on)

Note: Do not turn off the power during the 10 minutes otherwise the ChargeHub will be damaged.

# D. Appendix

The following documents are the product design standards:

- IEC 61851-1:2017 Electric vehicle conductive charging system –Part 1: General requirements
- IEC 61851-21-2:2018 Electric vehicle conductive charging system –Part 21-2: Electric vehicle requirements for conductive connection to an AC/DC supply – EMC requirements for off-board electric vehicle charging systems
- IEC 60068-2 Environmental testing
- IEC 60068-2-1:2007 Environmental testing - Part 2-1: Tests - Test A: Cold
- IEC 60068-2-2:2007 Environmental testing - Part 2-2: Tests - Test B: Dry heat
- IEC 60068-2-30:2005 Environmental testing - Part 2-30: Tests - Test Db: Damp heat, cyclic (12 h + 12 h cycle)
- IEC 60068-2-78:2012 Environmental testing – Part 2-78: Tests – Test Cab: Damp heat, IEC 61000-4 Electromagnetic compatibility (EMC)
- IEC 61000-4-2:2008, Electromagnetic compatibility (EMC) – Part 4-2: Testing and measurement techniques – Electrostatic discharge immunity test
- IEC 61000-4-3:2006, Electromagnetic compatibility (EMC) – Part 4-3: Testing and measurement techniques – Radiated, radio-frequency, electromagnetic field immunity test
- IEC 61000-4-4:2012, Electromagnetic compatibility (EMC) – Part 4-4: Testing and measurement techniques – Electrical fast transient/burst immunity test
- IEC 61000-4-5:2014, Electromagnetic compatibility (EMC) – Part 4-5: Testing and measurement techniques – Surge immunity test
- IEC 61000-4-6:2013, Electromagnetic compatibility (EMC) – Part 4-6: Testing and measurement techniques – Immunity to conducted disturbances, induced by radio-frequency fields
- IEC 61000-4-11:2004, Electromagnetic compatibility (EMC) – Part 4-11: Testing and measurement techniques – Voltage dips, short interruptions and voltage variations immunity tests steady state
- IEC 60950-1:2005 Information technology equipment - Safety - Part 1: General requirements
- BS EN 62196-1:2014 Plugs, socket-outlets, vehicle connectors and vehicle inlets — Conductive charging of electric vehicles - Part 1: General requirements
- IEC 62196-3:2014 Plugs, socket-outlets, vehicle connectors and vehicle inlets – Conductive charging of electric vehicles –Part 3: Dimensional compatibility and interchangeability requirements for d.c. and a.c./d.c. pin and contact-tube vehicle couplers

## E. Warranty Policy

These warranty terms and conditions are applicable by SAIC Motor Australia Pty. Ltd. (MG Motor) and cover the supply of the MG Aurora Charge Hub (Warranty).

Our goods come with guarantees that cannot be excluded under the Australian Consumer Law. You are entitled to a replacement or refund for a major failure and compensation for any other reasonably foreseeable loss or damage. You are also entitled to have the goods repaired or replaced if the goods fail to be of acceptable quality and the failure does not amount to a major failure.

The rights described in this Warranty are in addition to the rights you have as a consumer under the Australian Consumer Law. This Warranty does not purport to limit liability or alter your rights as a consumer that cannot be excluded under applicable law, including the Australian Consumer Law.

### I. What is covered by this Warranty

Unless otherwise specified in writing by MG Motor and subject to the terms of this Warranty policy, MG Motor warrants that any MG Aurora 7kW or MG Aurora 11kW Charge Hub (MG Charge Hub) supplied by MG Motor will be free from manufacturing defects or malfunctions during normal use for the following periods (each a Warranty Period):

- a. in respect of the RFID card supplied with each MG Charge Hub, 1 year from the date of original delivery; and
- b. in respect of all other aspects of the MG Charge Hub:
  - i. if supplied to MG Motor dealerships for the purpose of installation at the dealer's facility location, 3 years from the date of original delivery;
  - ii. if supplied to hotels, resorts and other business venues that are not MG Motor dealerships, for the purpose of installation at the business' location, 1 year from the date of original delivery; and
  - iii. if supplied to individuals for the purpose of installation at a residential address, 3 years from the date of original delivery.

To be entitled to claim under this Warranty, the defect or malfunction in the MG Charger Hub must appear within the applicable Warranty Period.

### 2. Exclusions (subject to the Australian Consumer Law)

To the maximum extent permitted by law and subject to the Australian Consumer Law, MG Motor is not liable under this Warranty for or in respect of:

- a. any accessories or other items separate to the MG Charge Hub (for example, connecting cables that are separately supplied);
- b. normal wear and tear;
- c. minor issues in the MG Charge Hub which do not substantially interfere with the ordinary use of the MG Charge Hub (for example, changes in cosmetic appearance that do not affect performance);
- d. unpaid or partly paid supplies;
- e. if MG Motor has supplied the MG Charge Hub as an "EV Aid", MG Charge Hubs that are not installed within 3 months from the date of original delivery;
- f. defects notified to MG Motor later than 7 calendar days from the discovery of such defect;
- g. any defect that is unrelated to the condition of the MG Charge Hub at the time it was supplied to you, including damage or faults caused by:
  - i. improper transportation, storage or installation of the MG Charge Hub after the date of original delivery;
  - ii. modification, alteration, disassembly or attempted repair of the MG Charge Hub by any person other than MG Motor or its authorised representative;
  - iii. operation or maintenance that is not in accordance with the MG Charge Hub instructions



manual, including where the MG Charge Hub is not used with the specified power supply requirements;

- iv. improper climate and environmental conditions where the MG Charge Hub is placed, installed or used, including where the MG Charge Hub is exposed to direct sunlight, rain or snow; or
- v. fire, water damage, power surges, accidental breakage or other events outside of MG Motor's reasonable control, including any lost, stolen or damaged MG Charge Hubs or parts of MG Charge Hubs (for example, the RFID card); and
- h. with respect to individuals who purchase the MG Charge Hub for installation at a residential address, use of the MG Charge Hub for a commercial purpose.

This Warranty is not transferable. It is limited to the original customer specified in the original tax invoice or supply agreement.

A Warranty for any MG Charge Hub (including parts) that is repaired or replaced during an applicable Warranty Period, will expire at the same time as the Warranty for the product as originally supplied.

An exclusion described above may be discovered by you, by an electrician or by a person authorised by MG Motor. If the Warranty exclusion is confirmed by MG Motor, you may be charged associated labour and administration costs. If a Warranty exclusion is discovered during a repair by a person authorised by MG Motor, the repair will be stopped, you will be notified and a repair estimate may be provided.

### **3. How to make a claim under this Warranty**

To make a claim under this Warranty, you must:

- a. cease using the MG Charge Hub immediately after the defect or malfunction appears;
- b. notify MG Motor within 7 calendar days after the defect or malfunction appears; and
- c. provide MG Motor with a copy of the original tax invoice or supply agreement, and photos or videos evidencing the defect or malfunction.

To make a claim, you can contact 1800 64 2277 (1800 MG CARS) or by emailing [anz.evsupport@smil.com](mailto:anz.evsupport@smil.com).

Once a claim has been submitted, MG Motor will endeavour to assess your claim and respond within 10 business days.

You will bear the expense of making the claim. MG Motor will bear the expense of labour, freight and administrative costs if MG Motor assesses that a valid claim has been made under this Warranty policy.

### **4. Remedies**

If the MG Charge Hub is determined by MG Motor to have a manufacturing defect or malfunction within the terms of this Warranty policy, MG Motor will, at its own election, either replace the MG Charge Hub or component with the same or comparable model, or repair it.

Any available remedy under this Warranty relates to the MG Charge Hub only, and not any accessory or other item separate to the MG Charge Hub (for example, connecting cables that are separately supplied).

To the extent that the MG Charge Hub or component is capable of retaining user-generated data, you should be aware that repairs may result in the loss of that data.

### **5. What if I have questions or concerns?**

This Warranty is given by SAIC Motor Australia Pty. Ltd.

You may direct any questions or concerns to 1800 64 2277 (1800 MG CARS), [anz.evsupport@smil.com](mailto:anz.evsupport@smil.com) or:

SAIC Motor Australia Pty. Ltd.

Level 19

100 Arthur Street

North Sydney NSW 2060

# F. Equipment Accessories

## F.1 Equipment Accessories List

NO.	EQUIPMENT COMPONENT	QUANTITY	COMMENTS
1	AC charger	1	7kW/11kW Pin terminal:E6012-BLACK,KST*3 Round terminal:RVL5-4,KST*3 Ground terminal:AVKI6RD*1 11kW
2	Terminal connectors	1	Pin terminal:E2508-BLUE,KST*5 Round terminal:RV3-4,KST*5 Ground terminal:AVKI6RD*1
3	Wall hanging	1	Wall hanging*1 M6 Self-tapping screws*4 8mm diameter plastic expansion tube*4 M6 flower type pan head combination screw*2
4	RFID Card	2	/
5	User manual	1	/
6	Pedestal (Optional)	1	M3 flower type pan head combination screw*2 M4 flower type pan head combination screw*2 M6 flower type pan head combination screw*2 M10 Expansion bolt*4 M6 hexagon nut*1 Pedestal*1 Cable protection cover *1 Front decorative cover*1 Rear decorative cover*1



Electric for Everyone