

Front Protection Bar

Installation and Owner's manual







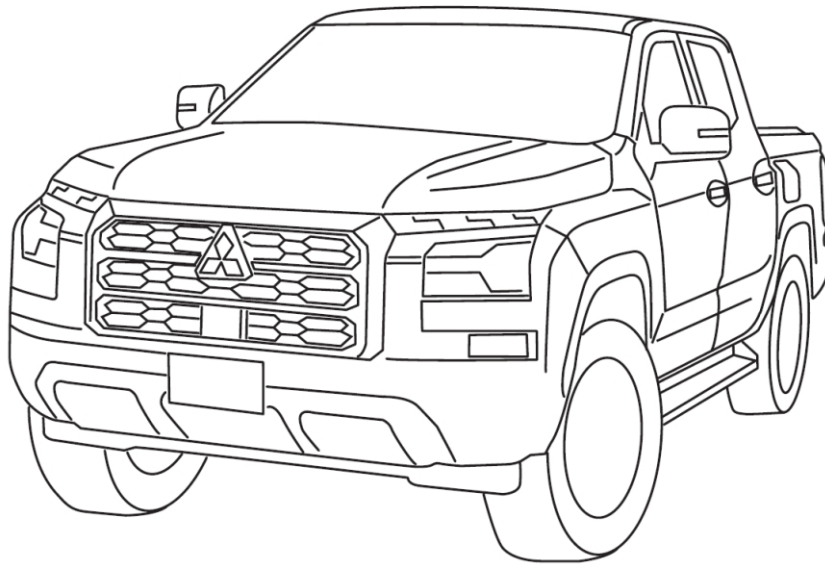

LA0 Parts No. MZ350757/758/759/760

- Thank you for purchasing the Mitsubishi Motors genuine accessory.
- The initial installation quality determines the level of performance, durability and trouble occurrence in the future.
- Make sure to read this manual carefully before installation of the product, and install it correctly after understanding an overall operation flow. Do not attempt installation other than instructed in this manual. We shall not be responsible for any failures occurred by not following the instructions in this manual.
- We recommend you to have the installation performed at an authorised Mitsubishi Motors dealer to ensure reliability.

Note

If the vehicle FCTA system (dealer option) is enabled, the fitment of Genuine Front Protection Bar will interfere with the operation of the vehicle's radar sensors. The FCTA system will need to be permanently disabled by an authorised Mitsubishi Motors dealer.



								
MZ350757	✓	✗	✓	✓	✓	✓	✓	STEEL <Type B> POWDER COATED
MZ350758	✓	✗	✓	✓	✓	✓	✓	STEEL <Type A> POWDER COATED
MZ350759	✓	✗	✓	✓	✓	✓	✓	ALLOY <Type B> POLISHED
MZ350760	✓	✗	✓	✓	✓	✓	✓	ALLOY <Type A> POLISHED

Symbol meaning



This symbol indicates a particularly important safety instruction. Read and follow it carefully for safety. Failure to heed the caution may result in death or serious human injuries.















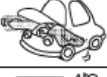

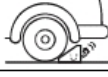

This symbol indicates a particularly important safety instruction. Read and follow it carefully for safety. Failure to heed the caution may result in human injuries or accidents.





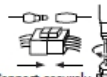







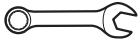
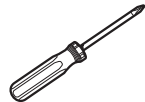
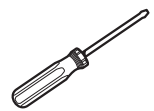
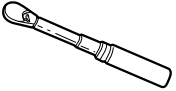

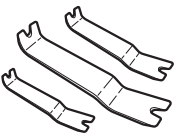

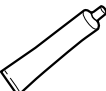
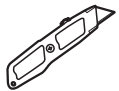
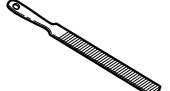

This symbol indicates an advisory instruction to follow during installation and handling.

Precautions for installation

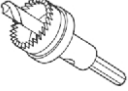
 Warning	
	Perform the installation indoors that is large enough without worrying about the rain and wind. Make sure the work area is well ventilated and take special care for the fullness of exhaust gas.
	Disconnect the negative terminal cable from the battery before installation. For the vehicle with the airbag, follow the instructions in the vehicle's workshop manual.
<ul style="list-style-type: none"> ● Do not install to the vehicles except for the applicable types. ● Do not install with remodeling. Failure to heed this caution may result in serious accidents. 	
 Caution	
	Work carefully using a protective cover to prevent the vehicle from scratches and dirt.
	When removing and reinstalling the vehicle body parts, refer to the vehicle's workshop manual.
	Be careful not to make a mistake when reinstalling the clips, screws, etc. removed from the vehicle.
	When jacking up the vehicle, make sure to use wheel chocks and work on a flat place.
	Tighten securely parts which the tightening torque is indicated according to the specified torque.
	When removing connectors, hold the connector bodies and unlock without pulling on harnesses. Do not destroy the connector lock by prying with a screw driver. Keep the harnesses away
	Do not pull on wiring harnesses strongly.
	Keep the harnesses away from hot engines, radiators, etc.
	Do not attach the harness to the brake piping or the air conditioner high pressure piping.
	Before the harness routing work, protect the terminals with a vinyl tape to prevent they will not be damaged.
	<ul style="list-style-type: none"> - Perform the harness routing with cable tie not to interfere with other parts. Also, cut the excess cable tie. (Especially, it is dangerous if the harnesses interfere the devices related to driving and braking.) - When attaching the harness with the cable tie, attach the cable tie with a degree of strength that the harness does not easily shift up and down or left and right.
	<ul style="list-style-type: none"> - Connect the wiring bullet terminal securely. - Refer to the following items for the connector connection. <ol style="list-style-type: none"> ① Check that it is locked visually. ② Check that it clicks. ③ Check that the connectors do not come off by pulling on the harnesses slightly. - Install the lead wire terminal securely to prevent the loosening by vibration.
	After the harness routing, check the operation of the parts installed before the recovery. It prevents the misrouting.
	Check that the electric components for the vehicle operate normally. Also, note the memory of the electric components such as a radio.
<ul style="list-style-type: none"> ● When inserting the terminals, make sure that the wire colour of the harness is correct. 	

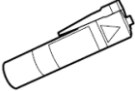
– Tools and Materials Required

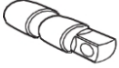
 Ratchet	 Socket Set - 10mm, 12mm, 13mm, 14mm (deep), 15mm, 16mm, 17mm, 18mm	 Hexalobular Socket Set - T20, T30, T40,	 Combi Spanner - 7mm, 10mm, 13mm, 14mm, 15mm, 17mm, 18mm	 Phillips Head Screwdriver	 Flat Blade Screwdriver
 Torque Wrench 3 - 77Nm	 Multi Tool	 Rivet Gun (if fitting Winch) Mandrel size 3.2mm (winch)	 Trim Removal Tools	 Steel Ruler	 Side Cutters
 Scissors	 Marker / Pen / Scribe	 Masking Tape	 Super Glue	 Knife or Bumper Cutting Tool	 File or Deburring Tool
 Centre Punch	 Battery Drill	 Hole Saw or Step Drill - Ø45mm	 Drill Bit - Ø2.0mm, Ø2.5mm, Ø3.5mm, Ø5.0mm, Ø6.0mm, Ø8.0mm	 Sikaflex 221 / Urethane	 Hammer
 Socket Extension	 Socket Swivel Adapter				

– Parts Supplied

Main Carton

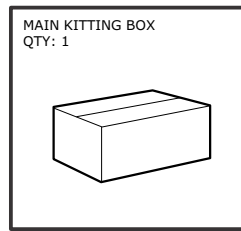
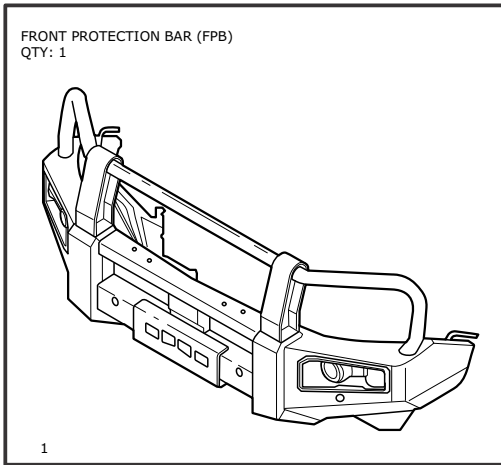

Main Fitting Kit - Box

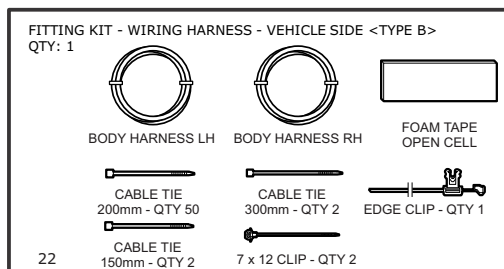
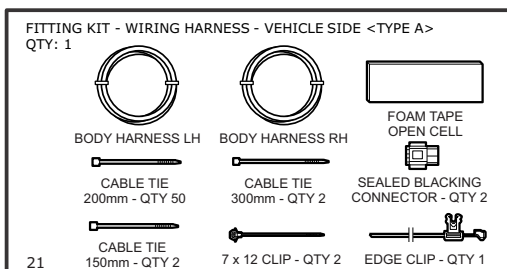
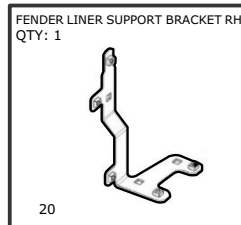
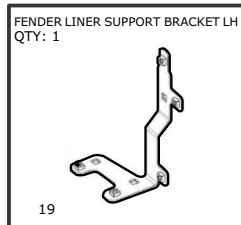
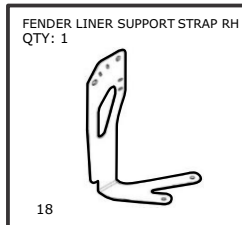
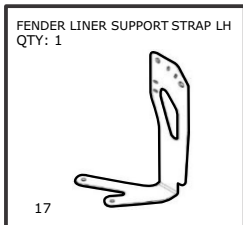
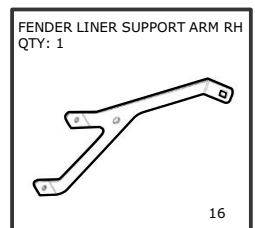
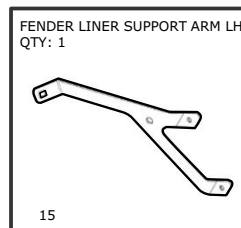
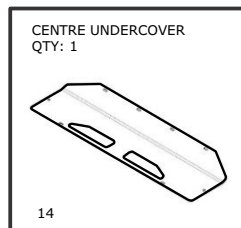
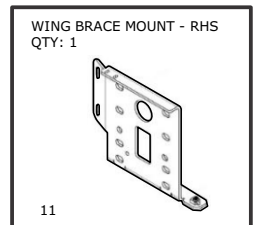
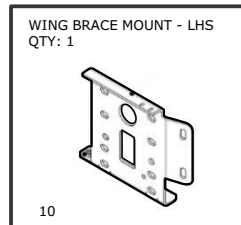
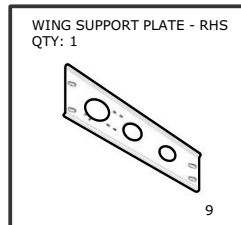
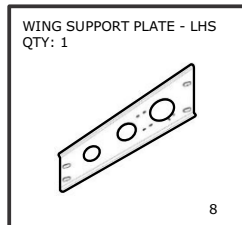
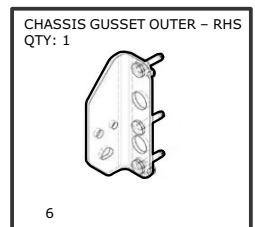
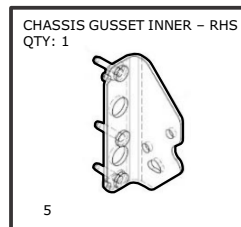
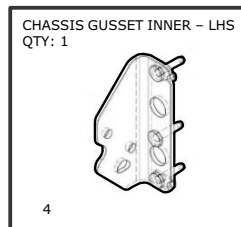
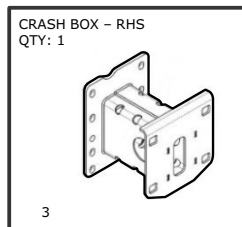
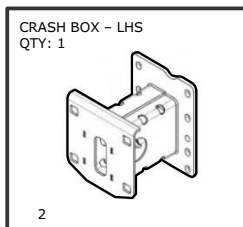

– Parts Supplied

Fitting Kit – FPB Mounting

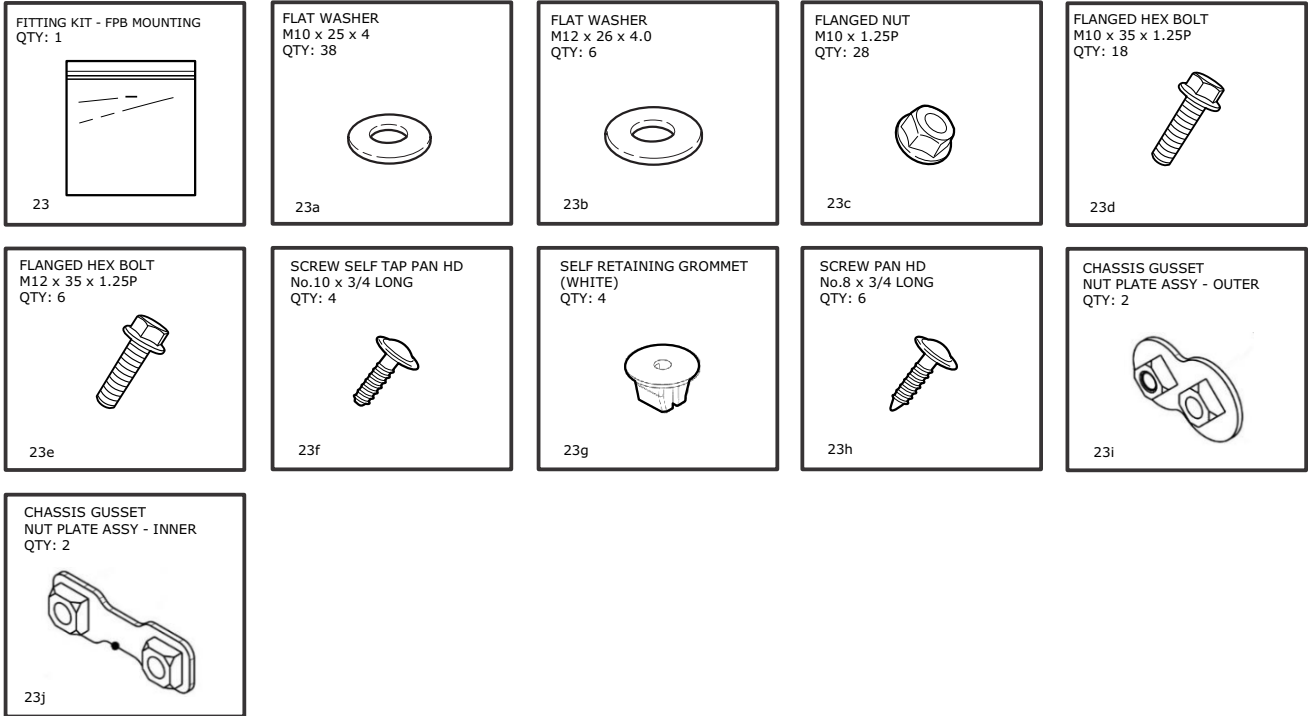

Fitting Kit – Undercover

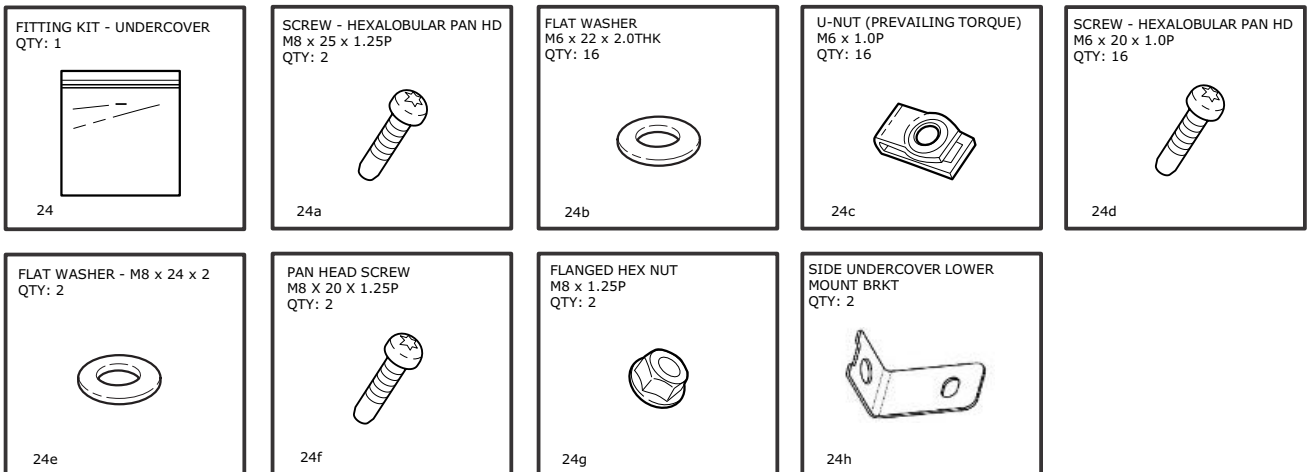

Fitting Kit – Radar

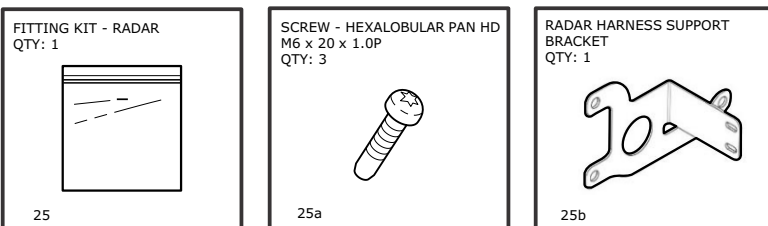

– Parts Supplied

Fitting Kit – Fender Liner Support

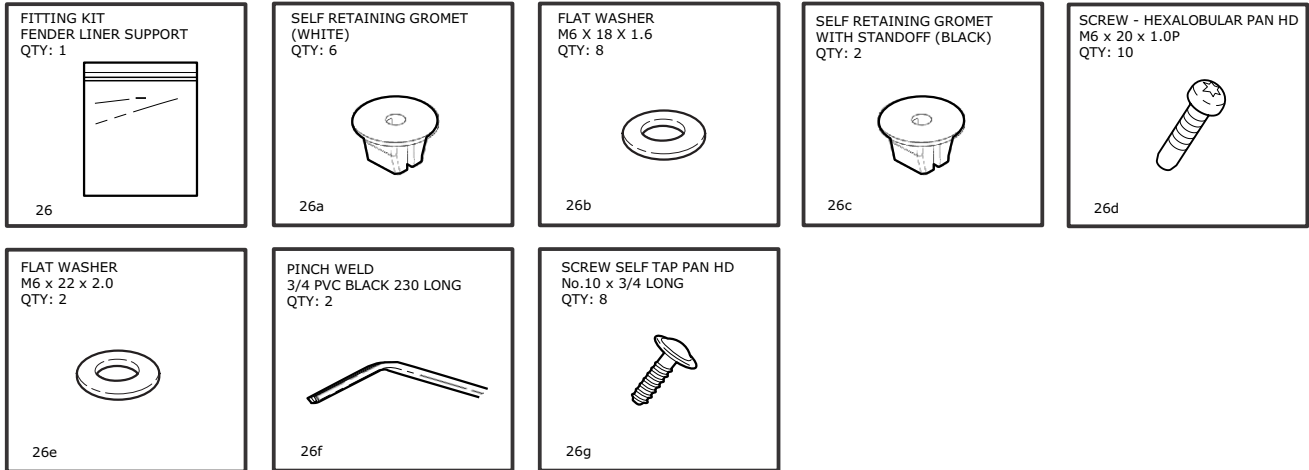

Fitting Kit – PVM Camera

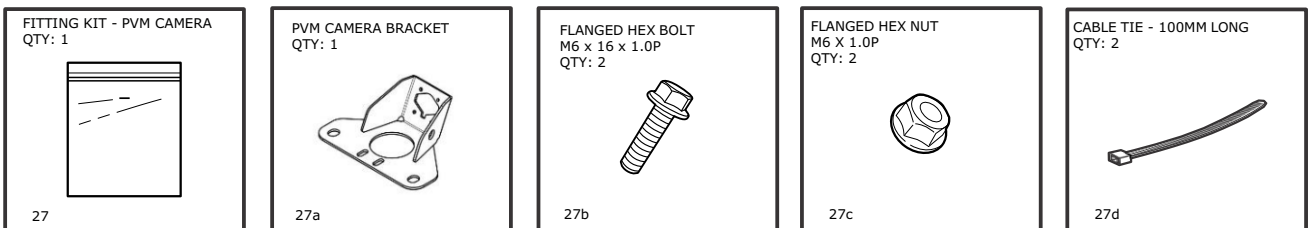

Fitting Kit – Spacers

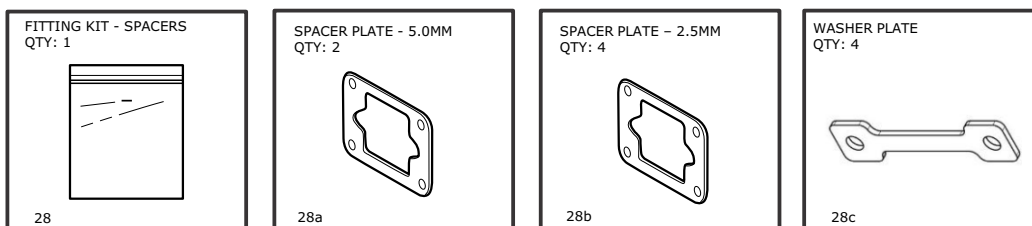

– Parts Supplied

Fitting Kit – Grille Support – <Type B> Vehicles Only

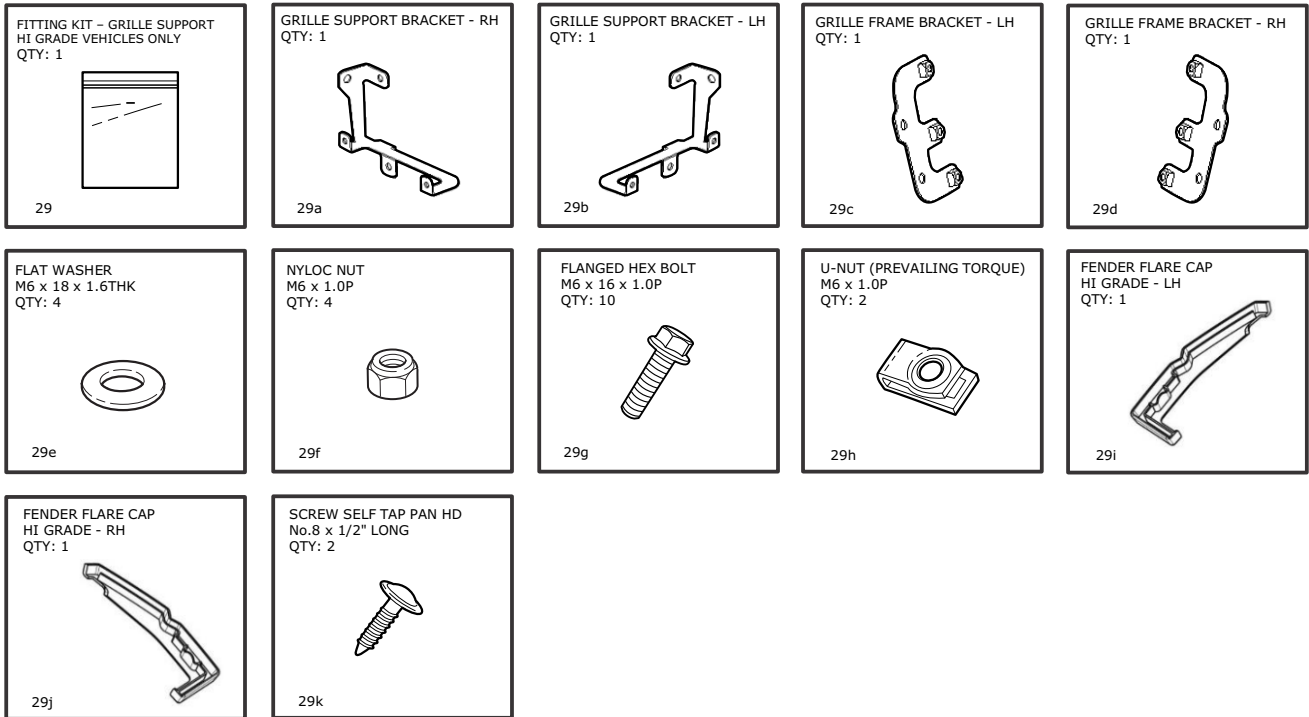

Fitting Kit – Grille Support – <Type A> Vehicles Only

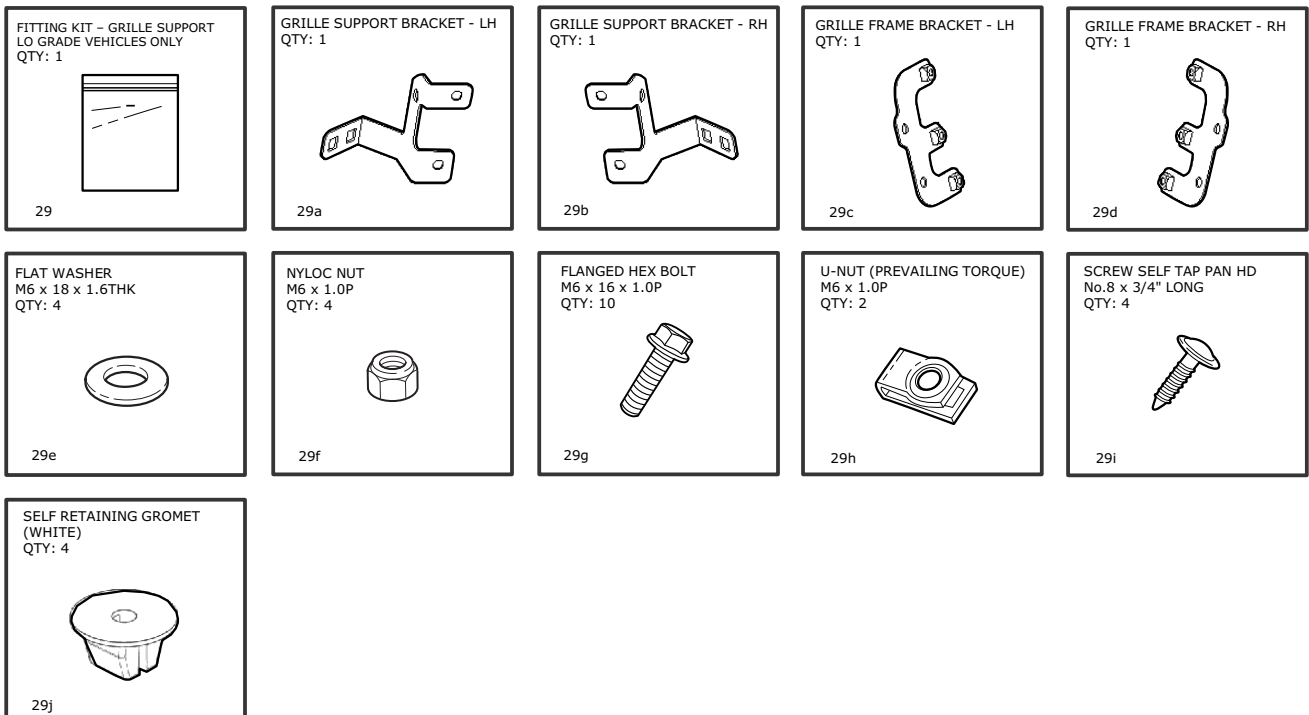

– Step 1

- Open the carton and identify all components from the parts supplied sheet.

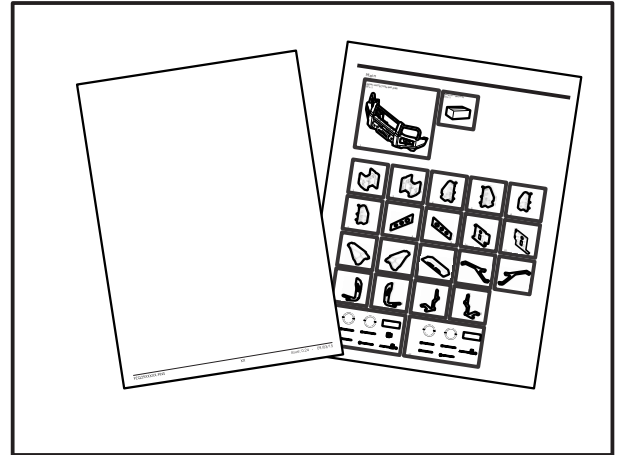

– Step 2

- Record FPB batch number on check sheet on last page of instructions.

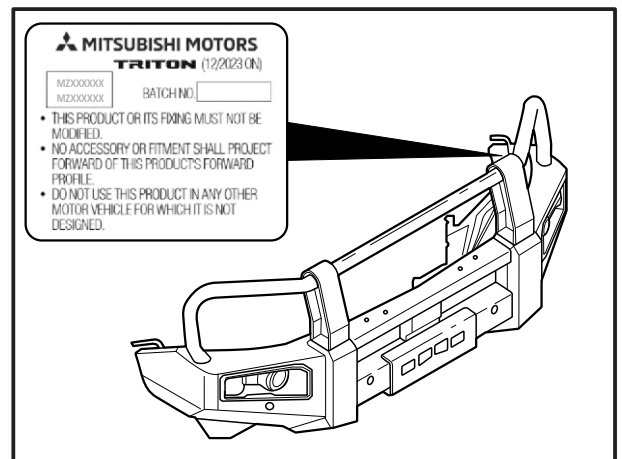

– Step 3

- Disconnect negative battery terminal following procedure as defined in vehicle's workshop manual.
- Cover the negative terminal with tape to prevent accidental contact.

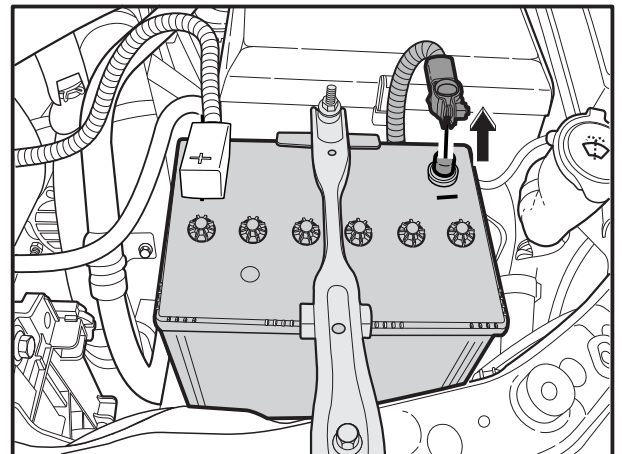

Tools Required: 

10mm spanner

— Step 4

Note

Refer to vehicle's workshop manual when removing components from the vehicle.

- Front Bumper Grille Cover (1).
- Radiator Grille (2).
- Fog Lamp Cover LH/RH (3).
- Front Air Spoiler LH/RH (4).
- Fender Flares (5) if fitted.
- Front Bumper assembly (6).

Tools Required:



Ratchet
10mm socket
Flat blade screwdriver
Trim removal tool
Phillips head screwdriver

<Type A>

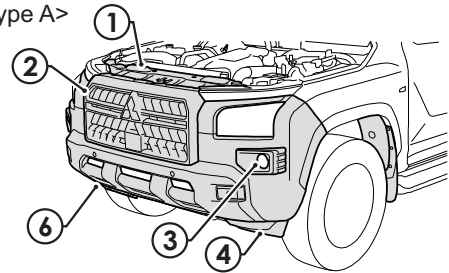

<Type B>

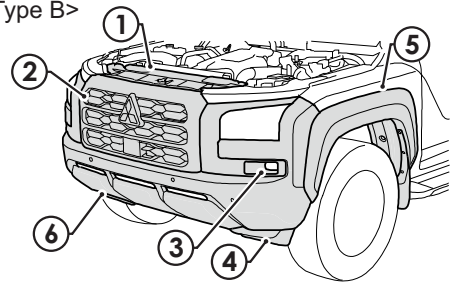

— Step 5

- Remove and retain push clip (1) from the plastic fender liner.

Tools Required:



Trim Removal tool

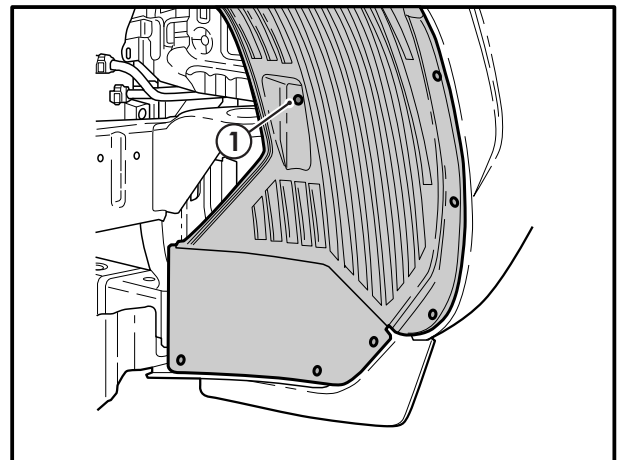

— Step 6

- Remove and retain 4x bolts from skid plate (1).

Note

If fitting winch cradle kit MZ350761 discard OE skid plate and retain fasteners.

- Remove and retain fasteners from engine room cover (2) if fitting winch cradle kit.

Tools Required:



Ratchet
12mm socket

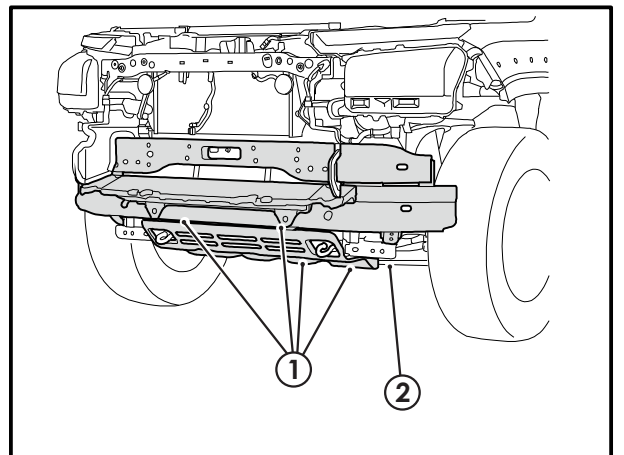

– Step 7

- Remove and discard foam crash absorber **(1)** by unscrewing plastic clips **(2)** using a Phillips head screwdriver or wedging trim removal tool under clips 2 places.

Tools Required: 

Trim removal tool
Phillips head screwdriver

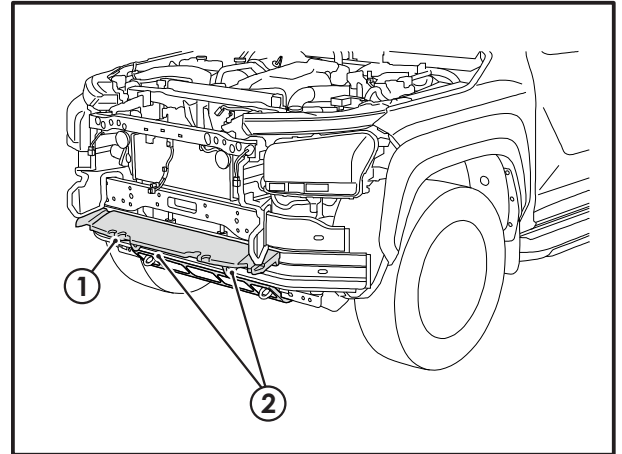

– Step 8

- Remove and discard front cross member **(1)** and lower mounting brackets **(2)** and fasteners.

Tools Required: 

Ratchet
14mm socket

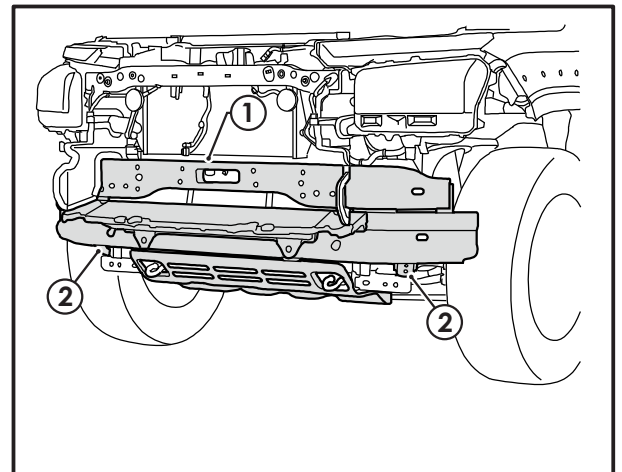

– Step 9

- Remove and discard bumper stays **(1)**.
- Retain 2 x M8 bolts per side **(2)**.
- Remove and discard radiator side air guide panel RH/LH **(3)**.

Tools Required: 

Ratchet
12mm socket
Trim removal tool

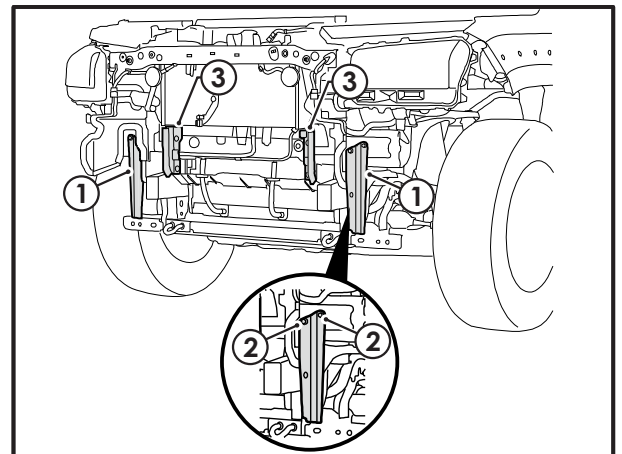

– Step 10 –

- Insert inboard nut plate **(1)** through end of chassis (RH) **(2)**. Ensure correct orientation as shown
- Loosely attach inboard chassis gusset **(3)** using 2 x M12x35mm flanged bolt **(5)** and 2 x M12x 4 Washers **(6)** as shown.
- **Repeat for LH chassis gusset.**

Note

Ensure correct orientation of chassis gusset and nut plate.

Tools Required: 
15mm socket/spanner

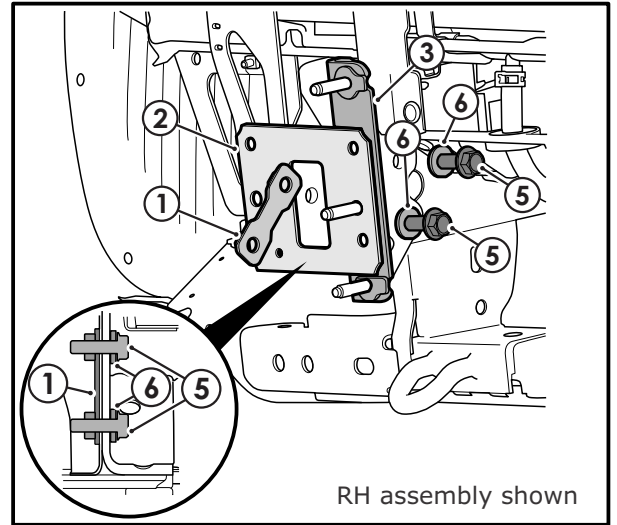

– Step 11 –

- Insert outboard nut plate **(1)** through end of chassis (RH) **(2)**. Ensure correct orientation as shown.
- Loosely attach outboard chassis gusset **(3)** using 1x M12x35mm flanged bolt and M12x 4 Washer **(5)** and M10x35mm flanged bolt and M10x 4 Washer **(6)** as shown.
- **Repeat for LH chassis gusset.**

Note

Ensure correct orientation of chassis gusset and nut plate.

Tools Required: 
Ratchet
13mm socket/spanner
15mm socket/spanner

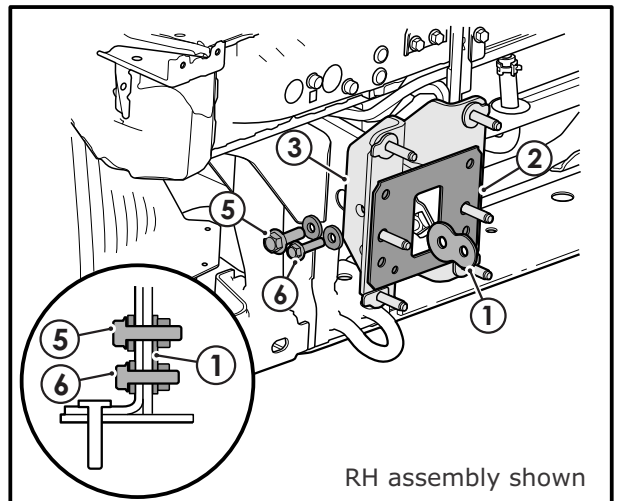

– Step 12.1 –

- Assemble the Fender Liner Support Bracket **(1)** to the Fender Liner Strap **(2)** using the 2 x supplied M6 x 20 hexalobular pan head bolts **(3)**.
- **Torque to 10 ~ 12Nm - 2 places** 
- Clip the 2 x White self-retaining grommets **(4)** into the square holes in the Fender Liner Support Bracket **(1)**.
- Clip the Black Stepped Self-Retaining Grommet **(5)** into the square hole in the Fender Liner Support Bracket **(1)**.
- **Repeat for LH bracket assembly.**

Tools Required: 
Torque Wrench
T30 Hexalobular drive

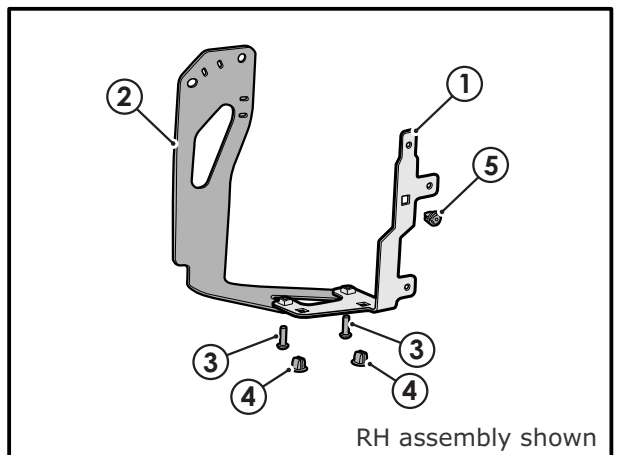

– Step 12.2 –

- Assemble the Fender Liner Support Arm (2) to the Fender Liner Support Bracket (1) using the 2 x supplied M6 x 20 hexalobular pan head bolts (3).
- **Torque to 10 ~ 12Nm - 2 places.** ⚠
- Clip the white self-retaining grommet (4) into the square hole in the Fender Liner Support Arm (2).
- Repeat for LH bracket assembly.

Tools Required:

Torque Wrench
T30 Hexalobular drive

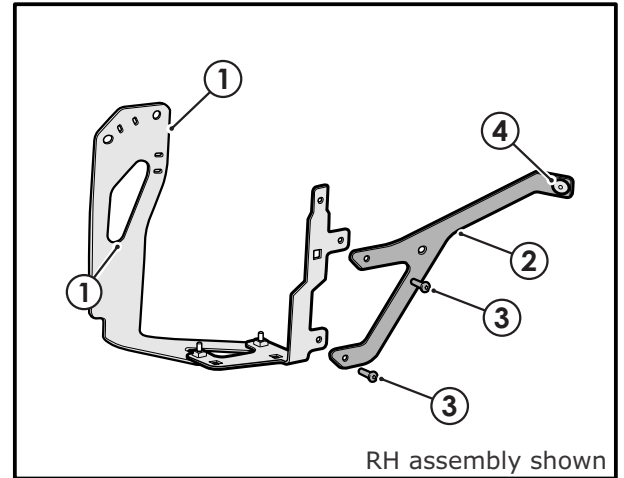

– Step 13.1 –

- Using the 2 x M8 bolts saved in step 9, Assemble the Fender Liner Support Bracket (1) to the chassis. Tighten firmly (do not torque).
- Mark the centre of 2 holes (2) in Fender liner (3) using the support bracket (1) as a guide.
- Using a 8.0mm drill bit in the power drill, drill two holes in the fender liner as shown (2).
- **Repeat for LH bracket assembly.**

Tools Required:

Ratchet
12mm socket
Power Drill
8.0mm Drill Bit

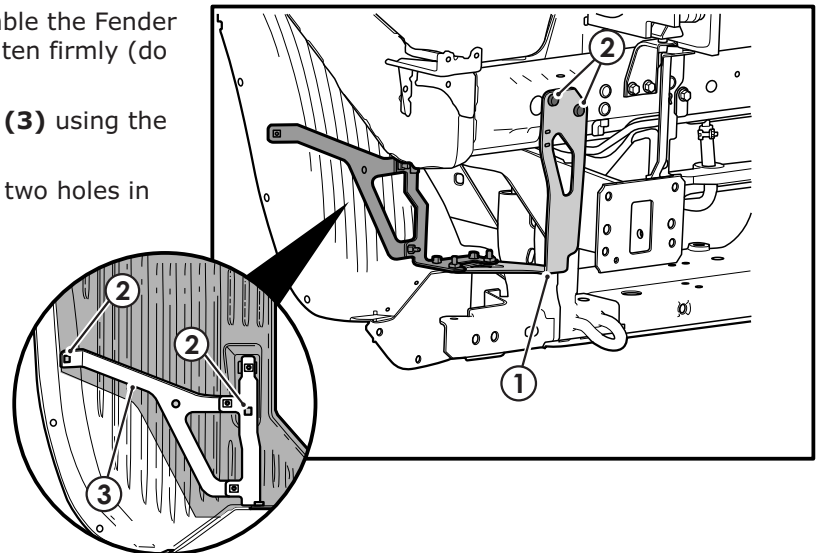

– Step 13.2 –

- Using the Fender Liner Support Bracket Assembly (1) as a guide, mark up the fender liner as shown.
- At the end of the Fender Liner Support Bracket (2) mark a line (3) parallel with the outer edge vertically to the Fender Liner Joggle (4).

Tools Required:

Ruler
Masking tape
Marker Pen

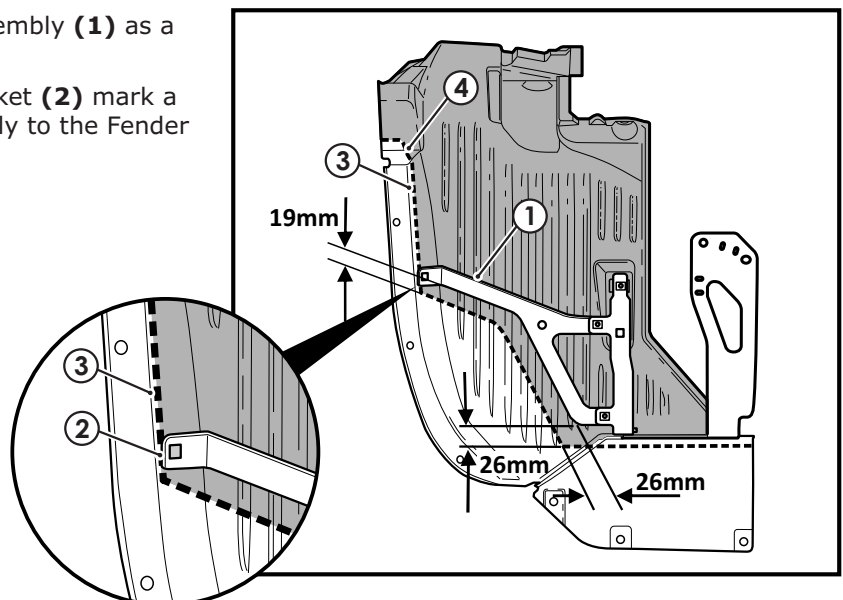

– Step 13.3

- Mark the fender liner inwards across car 26mm & down 50mm from feature **(1)** as shown.
- Mark a line **(2)** bridging previously marked lines.
- Remove the Fender Liner Support bracket fitted in Step 13.1
- Using the Multi tool, carefully cut the inner Fender Liner as marked up.
- Deburr and clean up any sharp edges.
- **Repeat for left side fender liner.**

Tools Required:

Multi tool or Tin Snips

Ruler

Masking tape

Marker Pen

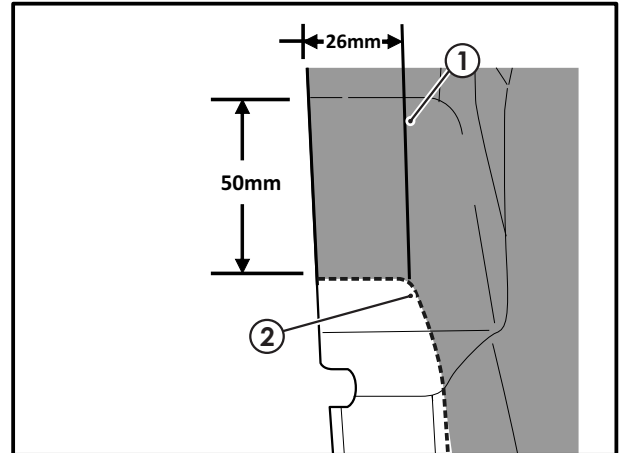

– Step 13.4

- Using a 2.5mm drill bit in the power drill, drill out the 2 x rivets **(1)** in the lower fender liner **(2)**.
- Using a 6.0mm drill bit in the power drill, drill out the 2 x rivet holes through the fender liner **(1)**.
- **Repeat for left side fender liner.**

Tools Required:

Power Drill

2.5mm Drill Bit

6.0mm Drill Bit

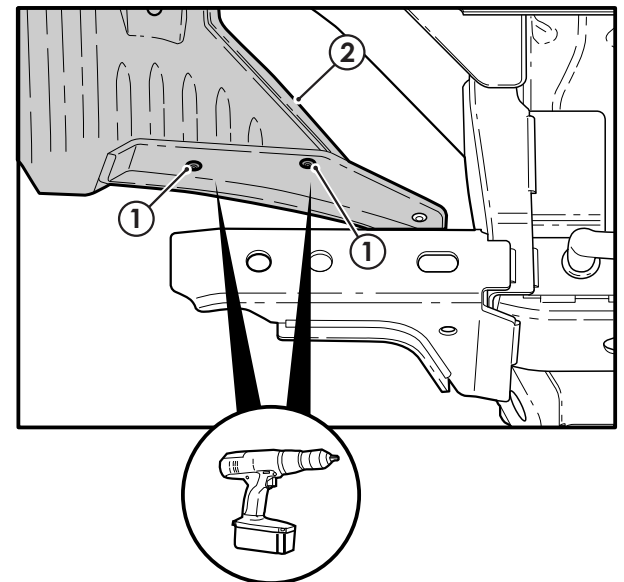

– Step 14

- Refit the Fender Liner Support assembly **(1)** using the two bolts saved from step 13.3 **(2)**.
- **Torque to 25 ~ 30Nm - 2 places. ⚠**
- Fasten the Fender Liner to the fender liner support bracket using the supplied 4x No 10 x 3/4 long Pan Head Screws **(3)** and 4 x M6 x 18 x 3 flat washers **(4)**. Tighten until just tight.
- Fasten the Fender Liner to the fender liner support bracket using the supplied M6 x 20 Pan Head Screw **(5)** and M6 x 22 flat washer **(6)**.
- **Torque to 10 ~ 12Nm - 1 place. ⚠**
- **Repeat for left side fender liner support bracket.**

Tools Required:

Torque Wrench

12mm socket

T30 Hexalobular drive

Phillips head Screwdriver

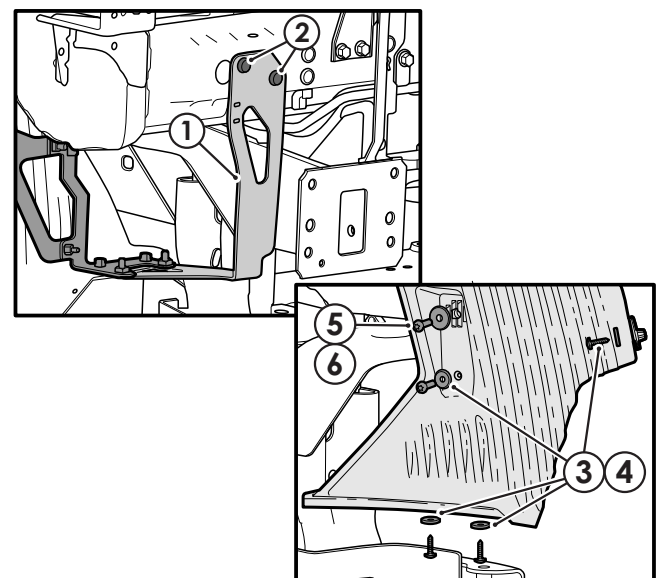

– Step 15

- Using a marker and ruler, mark cut lines **(1)** horizontal from the opening edge & **(2)** 95mm downwards as shown on both LH & RH air guides.
- Using the Multi tool, carefully cut the air guides in place on vehicle as marked up.
- Deburr and clean up any sharp edges.

Tools Required: 

Multi tool

Ruler

Masking tape

Marker Pen

File or deburring tool

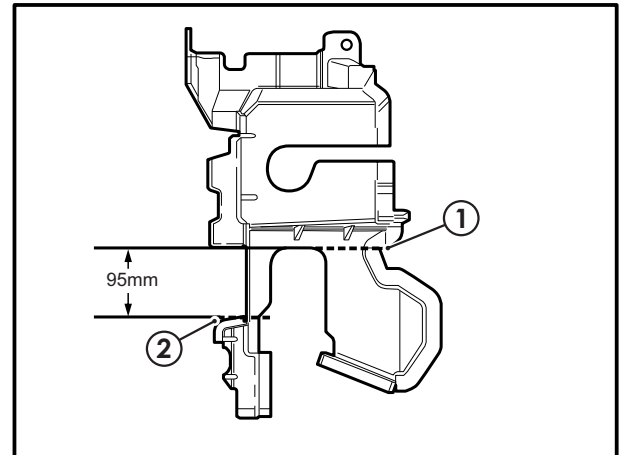

– Step 16

If fitting winch kit MZ350761 – go to step 19, otherwise continue with this step.

- Fit the RH wing brace support plate **(1)** over the RH chassis gusset plate studs as shown.
- Assemble the RH crash box **(2)** over the chassis gusset studs and hold in place with the 4 x M10 x 35 flanged bolt **(3)** and M10 washers **(4)**. Tighten Firmly.
- NOTE: circular cut out feature on the top edge of the crash box is on the outboard side of the vehicle as shown **(5)**.

Tools Required: 

Ratchet

13mm socket

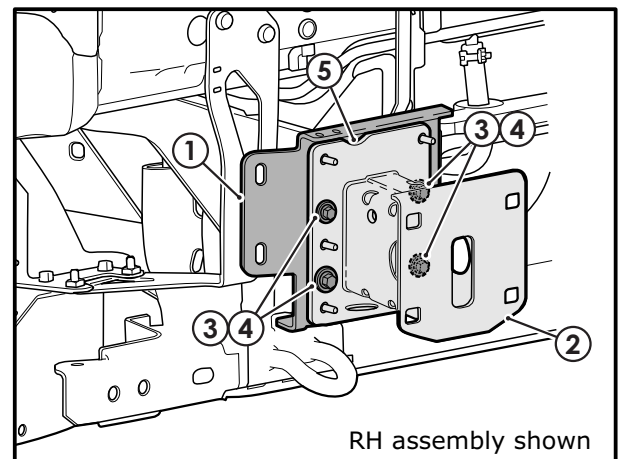

– Step 17

- Assemble 6x M10 flanged nuts **(1)** and M10x4 washers **(2)** onto the chassis gusset plate studs **(3)**. Tighten firmly.
- **Repeat Steps 16 & 17 for LH Crash Box.**

Tools Required: 

Ratchet

14mm deep socket

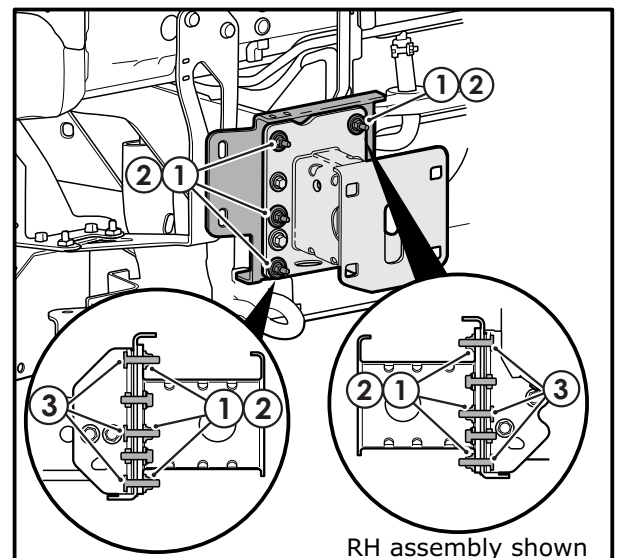

— Step 18 —

- Torque Inner & Outer Chassis Gusset bolts (1).
- **M12 – 77 ~ 85Nm - 3 places.** ⚠
- Torque Outer Chassis Gusset Bolts (2).
- **M10 – 70 ~ 75Nm - 1 place.** ⚠
- Torque crash box nuts (4).
- **M10 – 70 ~ 75Nm - 6 places.** ⚠
- Torque crash box bolts (3).
- **M10- 43 ~ 45Nm - 4 places.** ⚠
- **Repeat step 18 for LH Crash Box.**

Tools Required: 

Torque Wrench

13mm, 14mm deep socket & 15mm socket

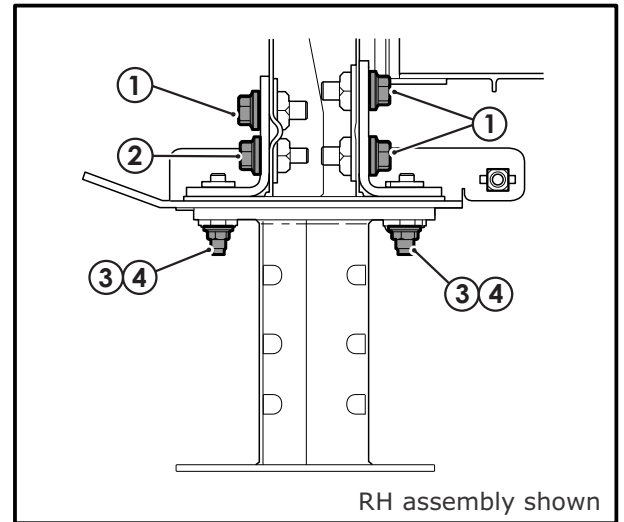

— Step 19 —

If installing a winch, refer to Installation instructions included with Genuine Winch Fitting Kit – MZ350761.

Tools Required: 

Refer accessory fitting instructions

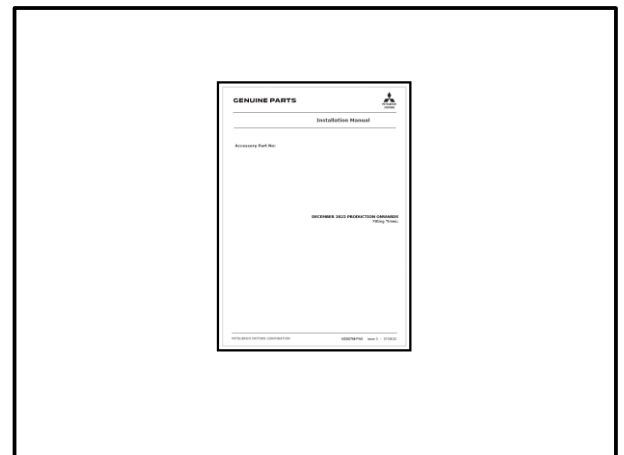

— Step 20 —

- Place the removed front bumper cover onto a suitable height work bench or panel stand.
- Remove and retain parking sensor & O-ring from the OE bumper for future fitment (1).
- If Fitted, Remove and retain bumper mounted lamps from OE bumper for future fitment (2).
- Remove and retain side Radars from OE bumper for future fitment (3).
- Remove and retain centre radar from OE bumper for future fitment (4).
- Remove and discard wiring harness (5).

Tools Required: 

Phillips Head Screwdriver

Ratchet

10mm Socket

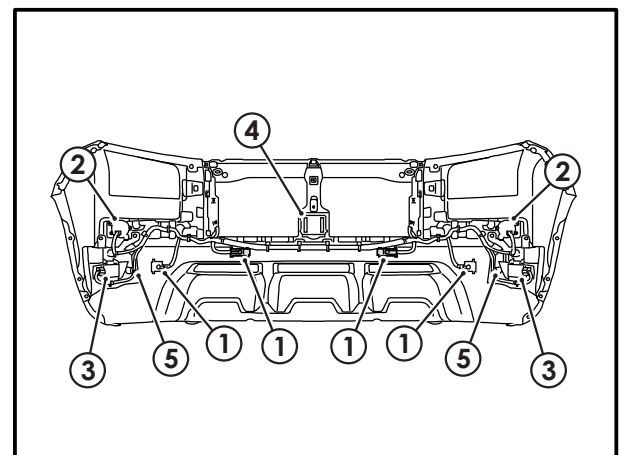

— Step 21 —

- Place the removed Radiator Grille onto a suitable height work bench or panel stand.
- If Fitted, remove and retain the front view camera for future fitment **(1)**.
- If fitted, Remove radiator Grille reinforcements (LH & RH) **(2)**.
- Retain 4 x screws for later use **(3)**. Discard all other screws and reinforcements **(2)**.

Tools Required: 

Phillips head screwdriver

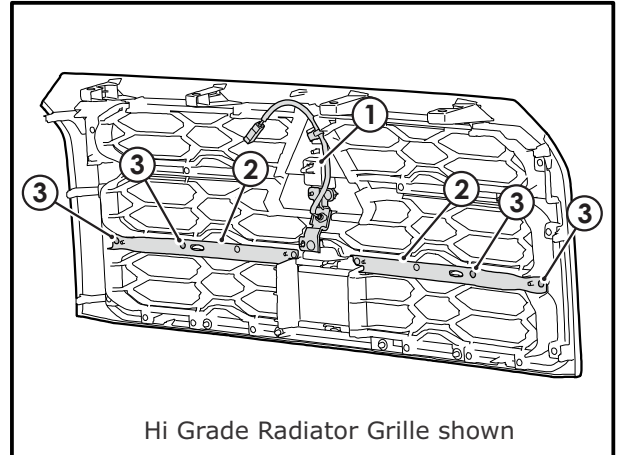

— Step 22 —

Cut vehicle components as required by following the cut instructions.

- **<Type A>** Vehicles, refer to Appendix 1.
- **<Type B>** Vehicles, refer to Appendix 2.
- For all cut templates, refer to supplied A3 template appendix.

Note

Ensure the correct cut template is used for the vehicle type, and ensure template scale is correct before commencing work.

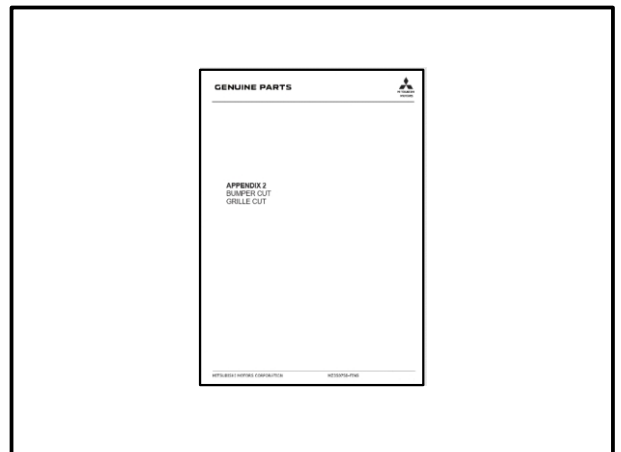

— Step 23.1 —

<Type B> Vehicles: continue with this step otherwise go to step 24.1.

- Fit the Grille support brackets **(1)** to the cut grille **(2)** by using the screws removed from the grille support in step 21, 4 places.
- Mark up the position for the M6 side bolt on the grille inner face using a marker pen or similar **(3)**.
- Remove and retain the grille support brackets and fasteners.

Tools Required: 

Phillips head screwdriver

Marker pen

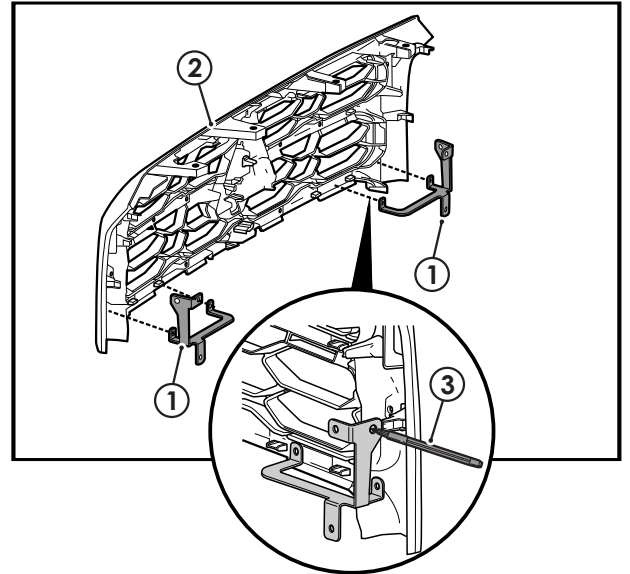

— Step 23.2 —

- Separate the grille outer **(1)** from the grille inner **(2)** by removing the 11 x screws.
- Drill a 8mm hole in the positions marked in previous step 23.1 on each side of the grille.
- Re-assemble the grille outer and inner.

Tools Required: 

Phillips head screwdriver

Power drill

8mm drill bit

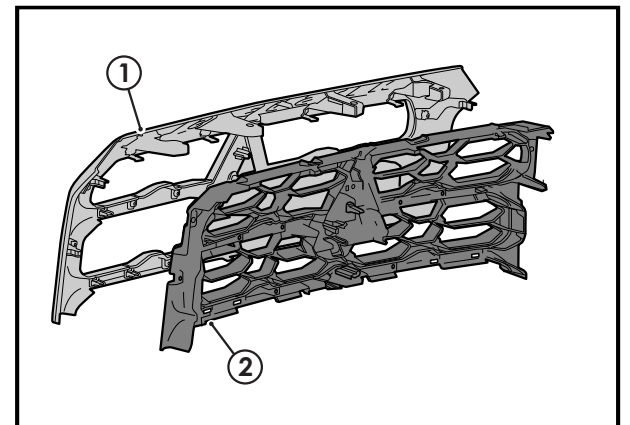

— Step 23.3 —

- Fit the supplied M6 U-Nut **(1)** to the top of each grille support bracket **(2)** as shown.
- Re-Fit Grille support brackets **(2)** to the cut grille **(3)** by using the screws **(4)** as per step 23.1.
- Fit the 2 x M6 x 16 bolts **(5)**.
- **Torque to 5 ~ 7Nm.** 

Tools Required: 

Phillips head screwdriver

Torque wrench

Ratchet

10mm socket

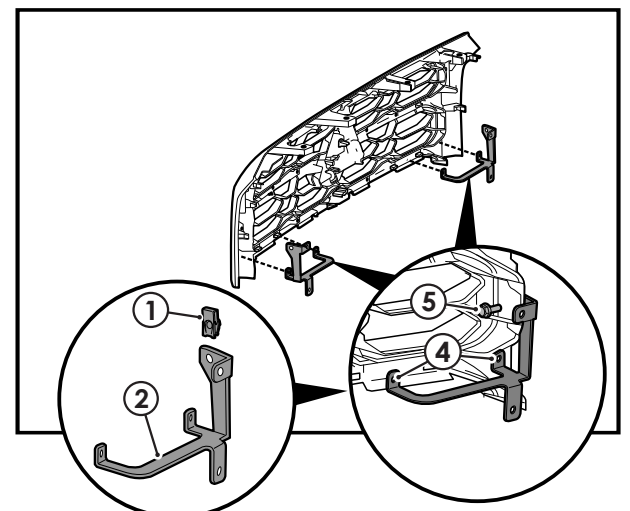

– Step 23.4

- Assemble the grille frame bracket **(1)** to the grille support bracket **(2)** using 2 x M6 x 16 bolts **(3)** (Both LH & RH sides).
- Fit the grille assembly **(4)** into the bumper **(5)** as shown.
- Mark the two hole positions per side **(6)** on the bumper using the grille frame brackets as a guide.
- Remove the grille **(4)** and drill 2 x 8mm holes (per side) where marked.

Tools Required: 

- 10mm spanner
- Power drill
- 8mm drill bit
- Marker pen

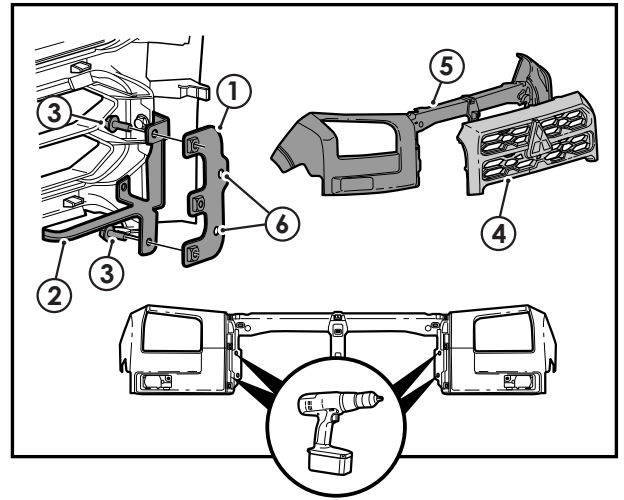

– Step 23.5

- Remove the Grille Frame Brackets from the Grille assembly.
- Fit the LH and RH Grille Frame brackets **(1)** to the bumper **(2)** using 2 x M6 bolts **(3)** M6 washers **(4)** and 2 x M6 Nylock nuts **(5)** per side.
- **Torque to 5 ~ 7 Nm.** 
- **Go to step 25.**

Tools Required: 

- Torque wrench
- 10mm socket
- 10mm spanner

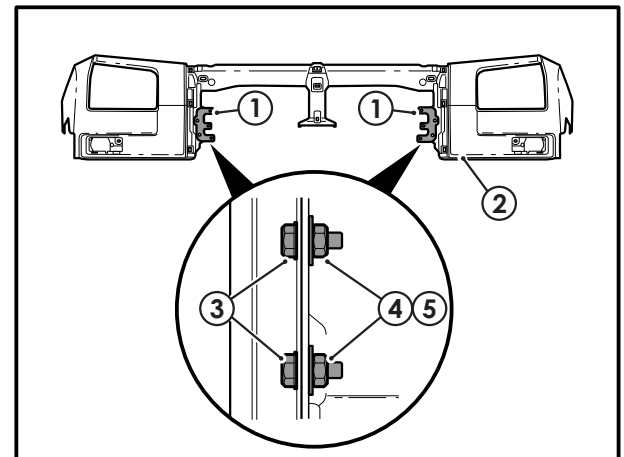

– Step 24.1

<Type A> Vehicles: continue with this step otherwise go to step 25:

- Offer the Grille Support Brackets (1) to the cut grille (2) as shown.
- Using a ruler, make sure the dimension from the bottom edge of the grill support bracket to the cut edge of the grille is 5.5mm (3).
- Mark the position for the M6 side bolt on the grille inner face (4).
- Mark the position for the 2 screws in the front face in the centre of the bracket square cutouts using a marker pen or similar (5).

Tools Required: 

Steel Ruler
Marker Pen

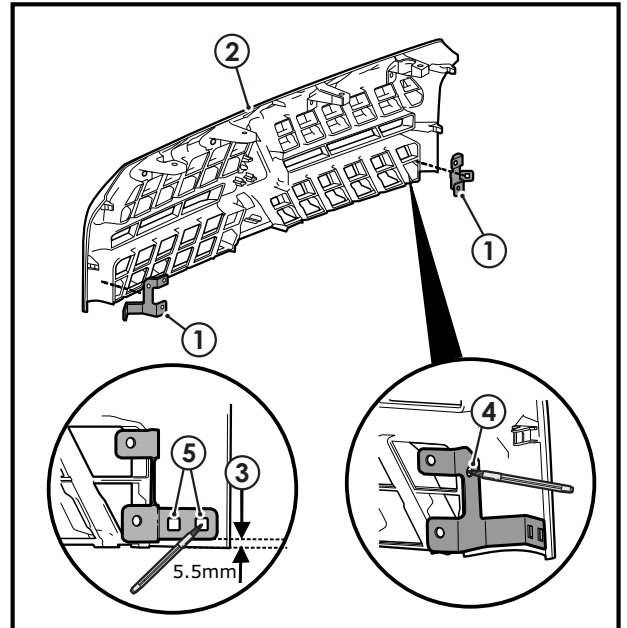

– Step 24.2

- Using the power drill with a 5.0mm drill bit, drill 4x holes (2 per side) where marked (1) through the front face of the grille.
- Using the power drill with a 8.0mm drill bit, drill 2x holes (1 per side) where marked (2) through the side face of the grille.

Tools Required: 

Power Drill
8mm & 5mm Drill Bits

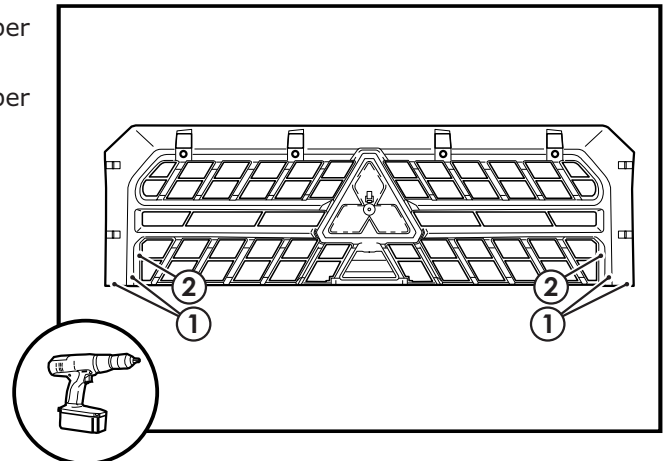

– Step 24.3

- Fit the supplied M6 U-Nut (1) and self-retaining grommets (2) to the grille support bracket (3) as shown
- Assemble the grille support brackets (3) to the grille using the supplied 1x M6 x 16 bolt (4) and 2x No8 x 3/4 screws (5) Per side

- **Torque M6 bolt to 5 ~ 7Nm. ⚠**
- **Torque No.8 x 3/4 screws to 1Nm or until just tight. ⚠**

Tools Required: 

Phillips head screwdriver
Torque wrench
Ratchet
10mm Socket

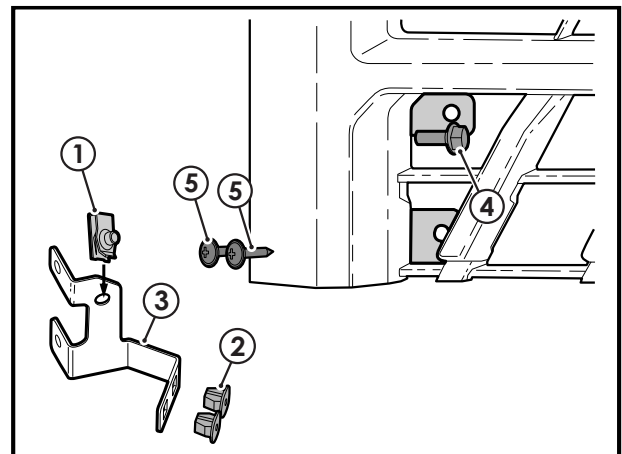

– Step 24.4 –

- Assemble the grille frame bracket (1) to the grille support bracket (2) using 2 x M6 x 16 bolts (3). (Both LH & RH sides).
- Fit the grille assembly (4) into the bumper (5) as shown.
- Mark the two hole positions (6) (per side) on the bumper using the grille frame brackets as a guide.
- Remove the grille (4) and drill 2 x 8.0mm holes (per side) where marked.

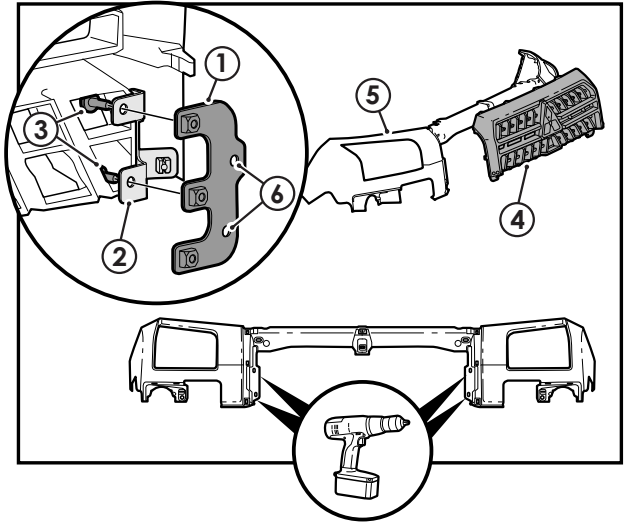

Tools Required: 

- 10mm spanner
- Power drill
- 8.0mm drill bit
- Marker pen

– Step 24.5 –

- Fit the LH and RH Grille Frame brackets (1) to the bumper (2) using 2 x M6 x 16 bolts (3) 2 x M6 washers (4) and 2 x M6 Nyloc nuts (5) per side.
- **Torque to 5 ~ 7Nm.** 

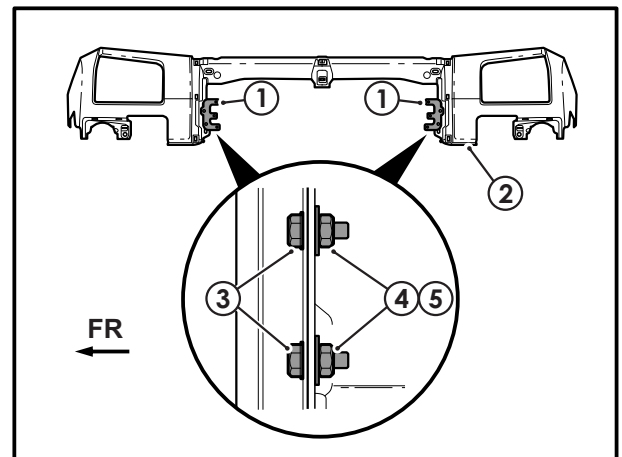

Tools Required: 

- 10mm spanner
- 10mm Socket
- Torque wrench

– Step 25.1 –

- Fit the LHS vehicle patch harness.
- Remove the LHS vehicle patch harness MZ350758-905 from the electrical fitting kit.
- Visibly confirm the correct harness is being used by noting the part number on the harness tag and a RED tape patch near the main harness connector.

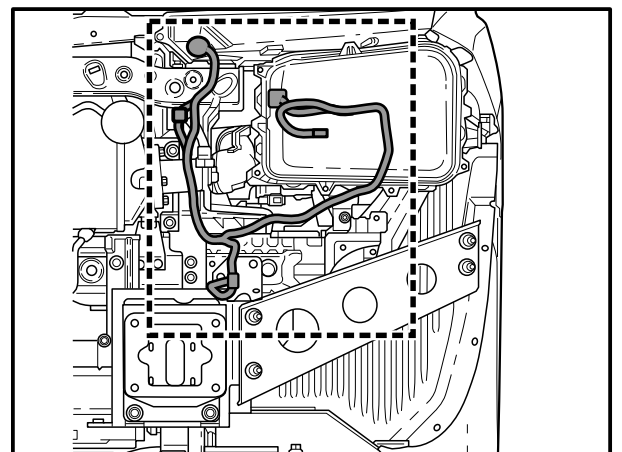
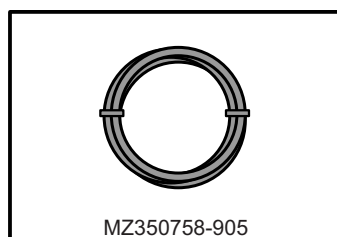

— Step 25.2 —

- Route the harness **(A)** as shown.
- Secure the white tape of the harness **(A)** to the vehicle in the position shown in the illustration with a cable tie **(1 - 2)**.
- Secure the harness **(A)** to the vehicle's harness with a cable tie **(3 - 6, 13)**.
- Trim excess cable tie lengths.

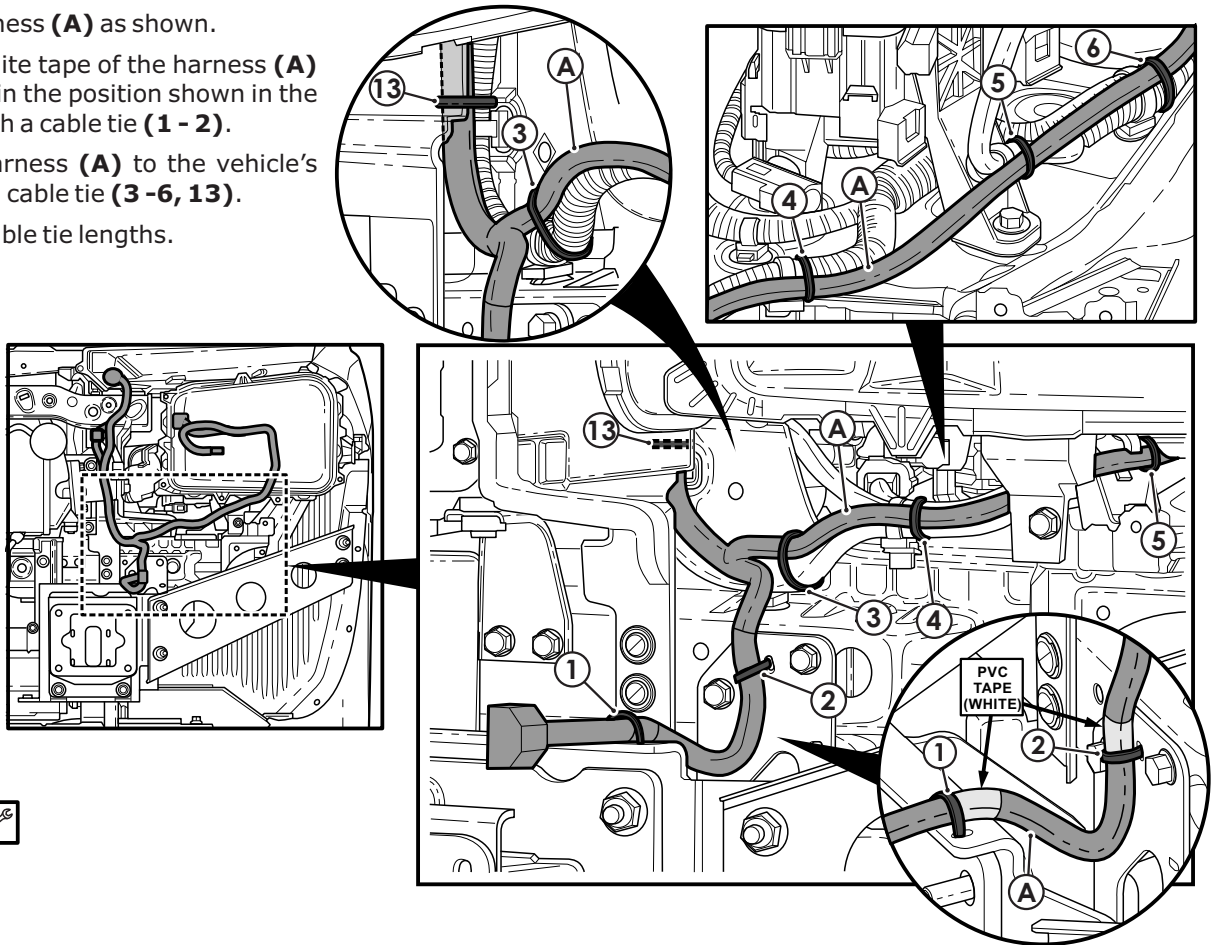

Tools Required: 

Side cutters

— Step 25.3 —

<Type A Vehicles>

- Route Harness (A) as shown.
- Disconnect the female connector (2-pin) of the vehicle COMB LP and connect it to the male connector (2-pin) of the harness (A).
- Connect the female connector (2-pin) of the harness (A) to the vehicle COMB LP.
- Secure with 200mm cable ties (7-12) to the vehicle harnesses where shown.
- Trim excess cable tie lengths.

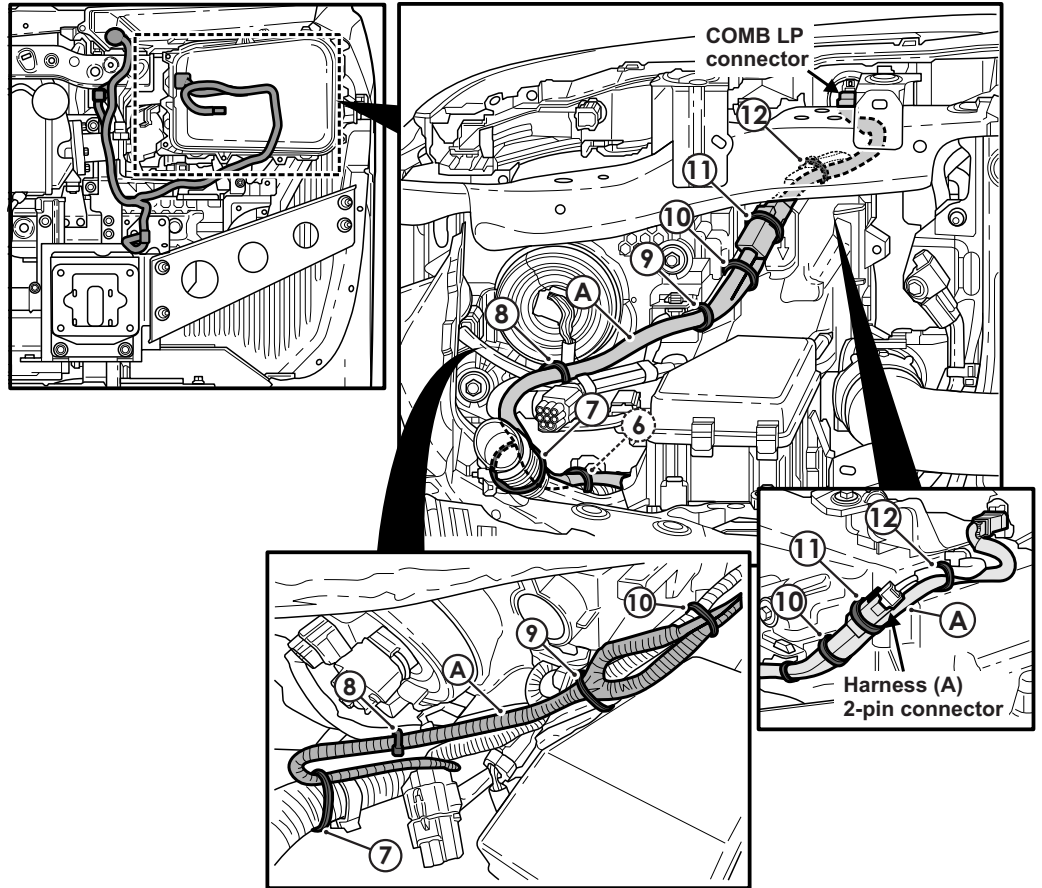

Tools Required: 

Side cutters

— Step 25.4 —

<Type B Vehicles>

- Route the Harness (A) as shown.
- Disconnect the female connector (2-pin) of the vehicle HEAD LP and connect it to the male connector (2-pin) of the harness (A).
- Connect the female connector (2-pin) of the harness (A) to the vehicle HEAD LP.
- Secure with 200mm cable ties (7-12) to the vehicle harness where shown.
- Trim excess cable tie lengths.

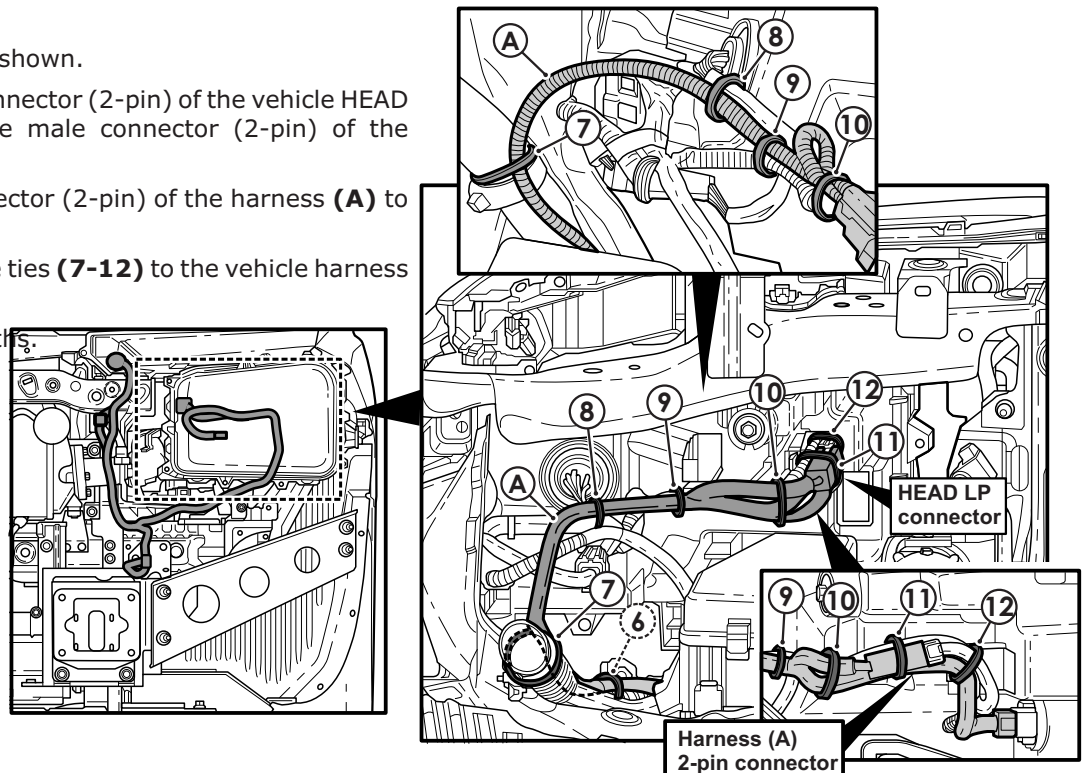

Tools Required: 

Side cutters

— Step 25.5 —

- Route the FPB Harness (BDY LH) **(A)** as shown.
- Disconnect the female connector (8-pin) of the vehicle COMB LP and connect it to the male connector (8-pin) of the harness **(A)**.
- Connect the female connector (8-pin) of the harness **(A)** to the vehicle COMB LP.
- Connect the female connector (8-pin) of the vehicle harness **(A)** to the male connector (8-pin) of the harness **(B)**.
- Secure with 200mm cable ties **(14-17)** and 150mm cable tie **(1)** to the vehicle harness **(B)** where shown.
- Trim excess cable tie lengths.

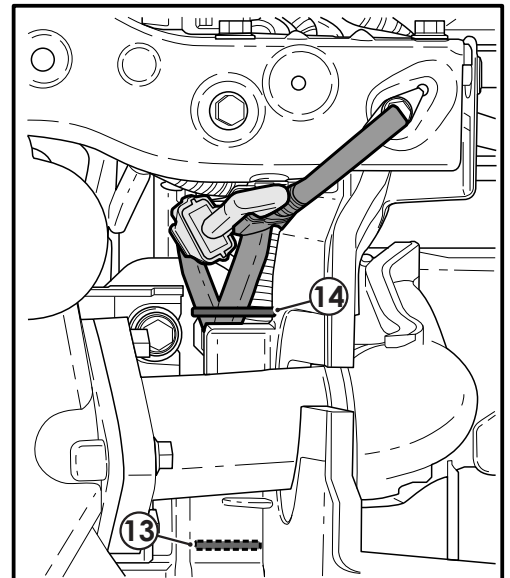
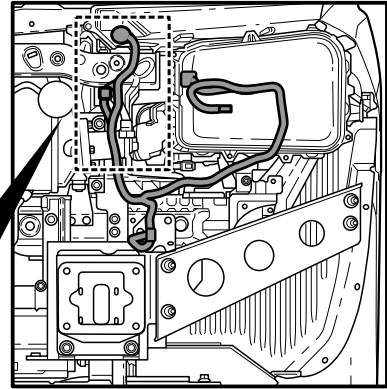

Tools Required: 

Side cutters

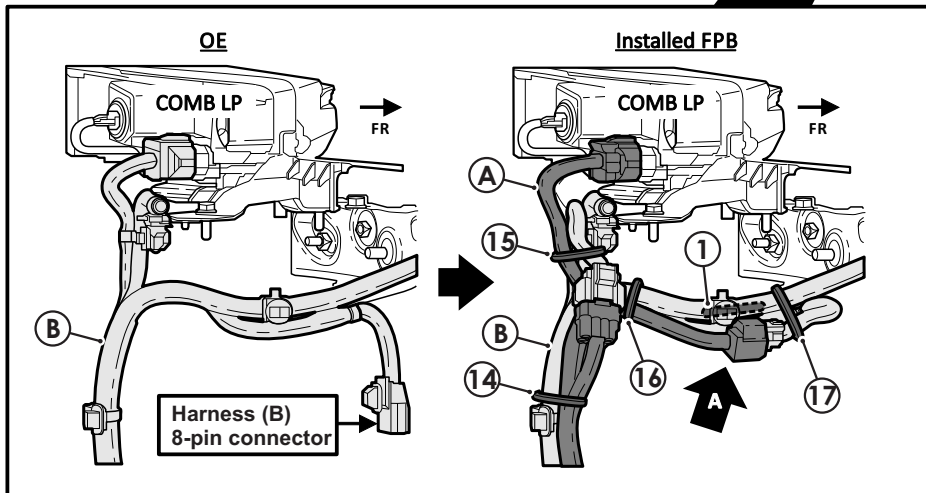

VIEW A

Pass the band cable tie **(1)** through the gap between the connectors and then secure the band to the vehicle harness **(B)**.

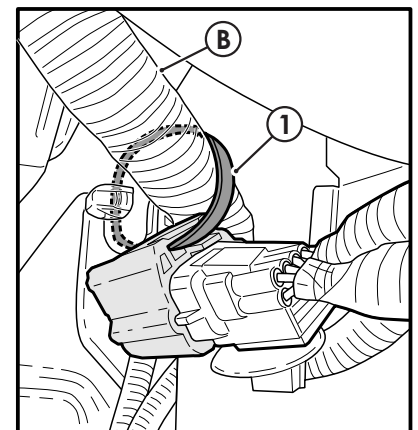
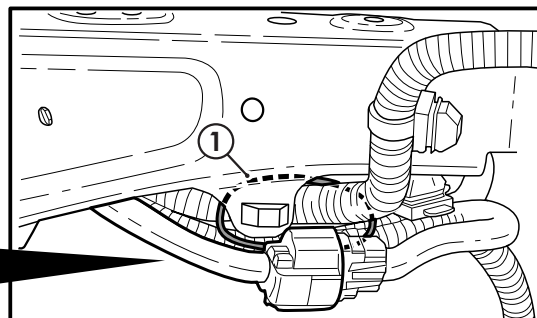
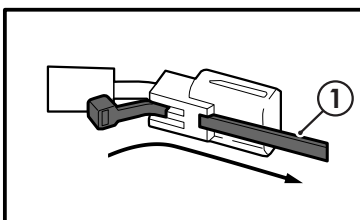

– Step 26.1

- Fit the RHS vehicle patch harness.
- Remove the RHS vehicle patch harness MZ350758-906 from the electrical fitting kit.
- Visibly confirm the correct harness is being used by noting the part number on the harness tag and a YELLOW tape patch near the main harness connector.

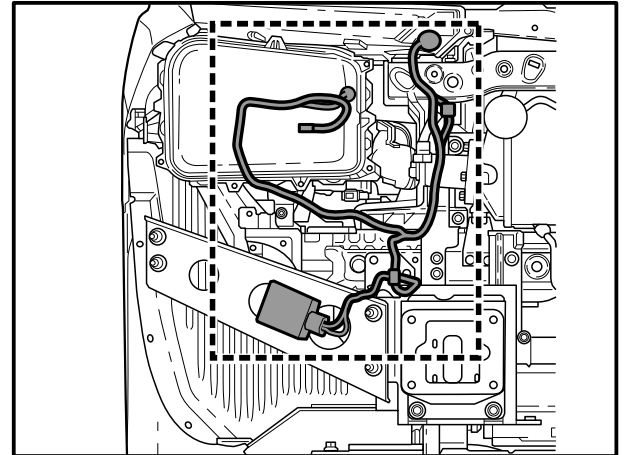
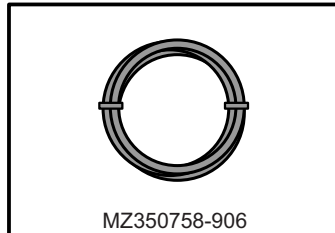

– Step 26.2

- Route the Harness (A) as shown.
- Secure the white tape of the harness (A) to the vehicle in the position shown in the illustration with a cable tie (18-19).
- Secure the harness (A) to the vehicle's harness with a cable tie (20, 22 - 25, 32).
- Trim excess cable tie lengths.

Tools Required: 

Side cutters

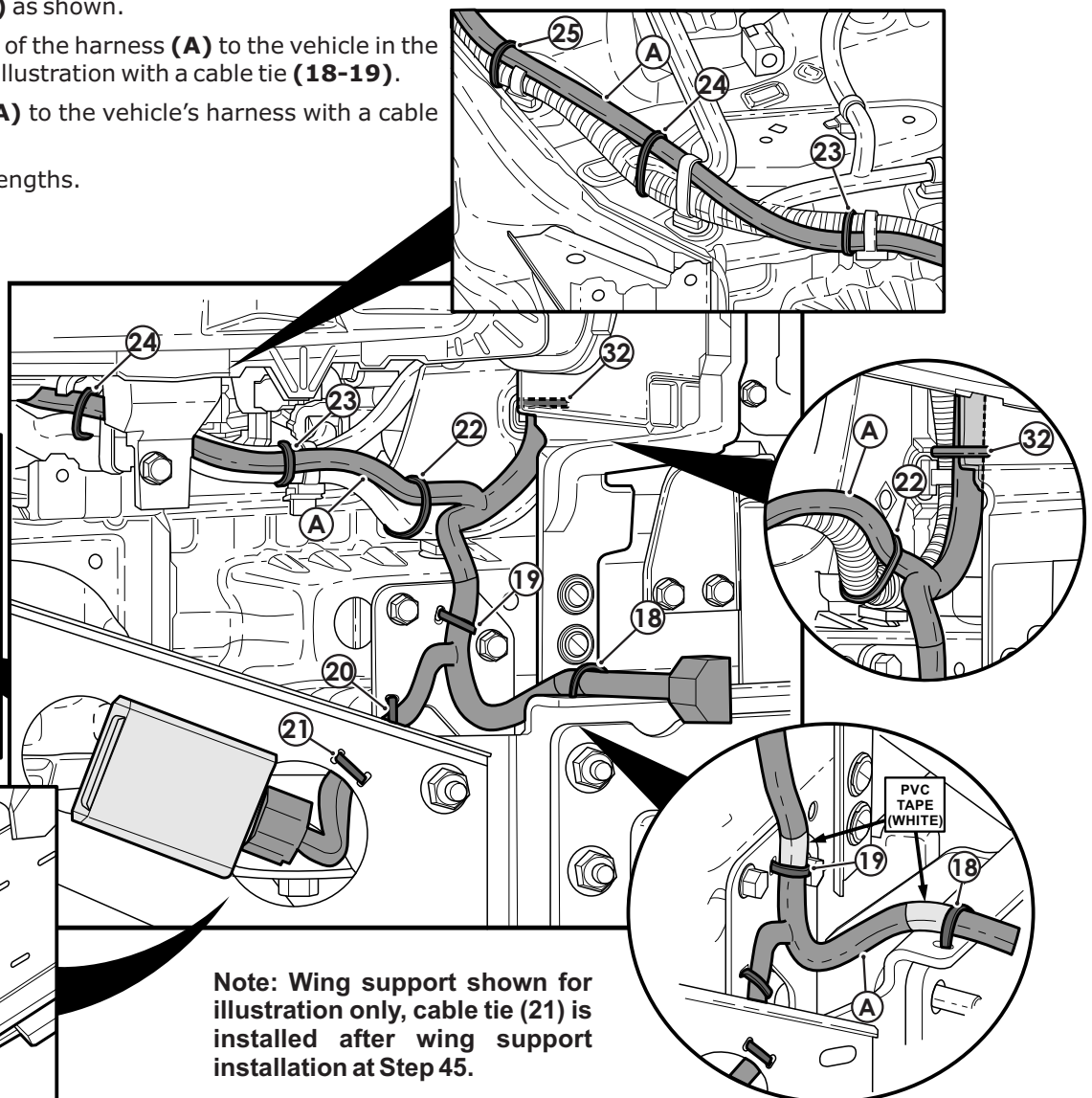
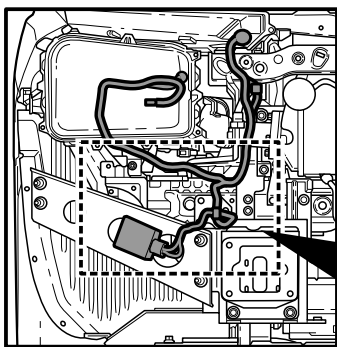

– Step 26.3 –

<Type A Vehicles>

- Route the Harness (A) as shown.
- Disconnect the female connector (2-pin) of the vehicle COMB LP and connect it to the male connector (2-pin) of the harness (A).
- Connect the female connector (2-pin) of the harness (A) to the vehicle COMB LP.
- Secure with 200mm cable ties (26-31) to the vehicle harness where shown.
- Trim excess cable tie lengths.

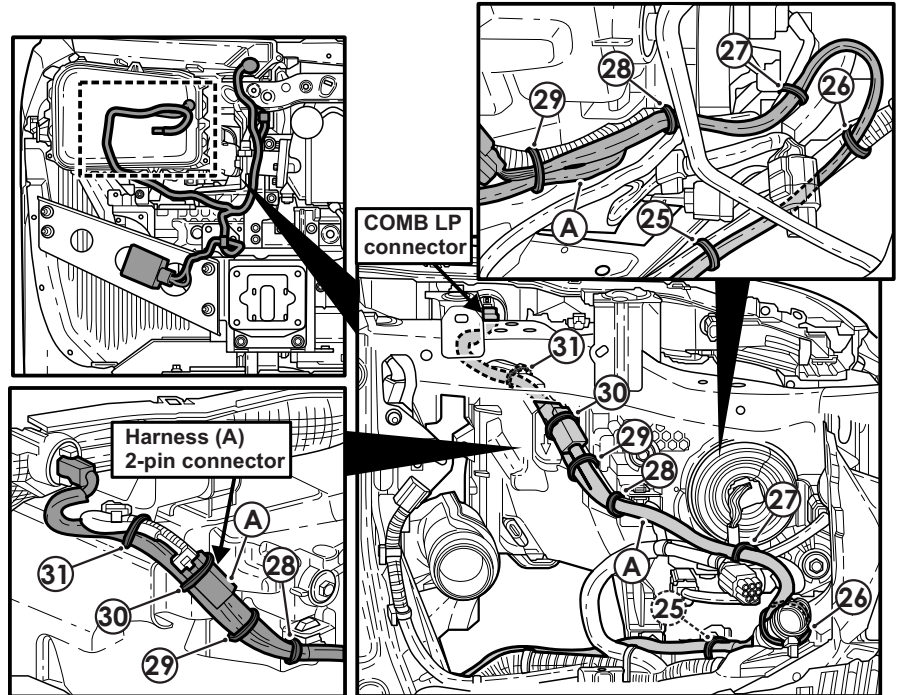

Tools Required: 
Side cutters

– Step 26.4 –

<Type B Vehicles>

- Route the Harness (A) as shown.
- Disconnect the female connector (2-pin) of the vehicle HEAD LP and connect it to the male connector (2-pin) of the harness (A).
- Connect the female connector (2-pin) of the harness (A) to the vehicle HEAD LP.
- Secure with 200mm cable ties (26-31) to the vehicle harness (B) where shown.
- Trim excess cable tie lengths.

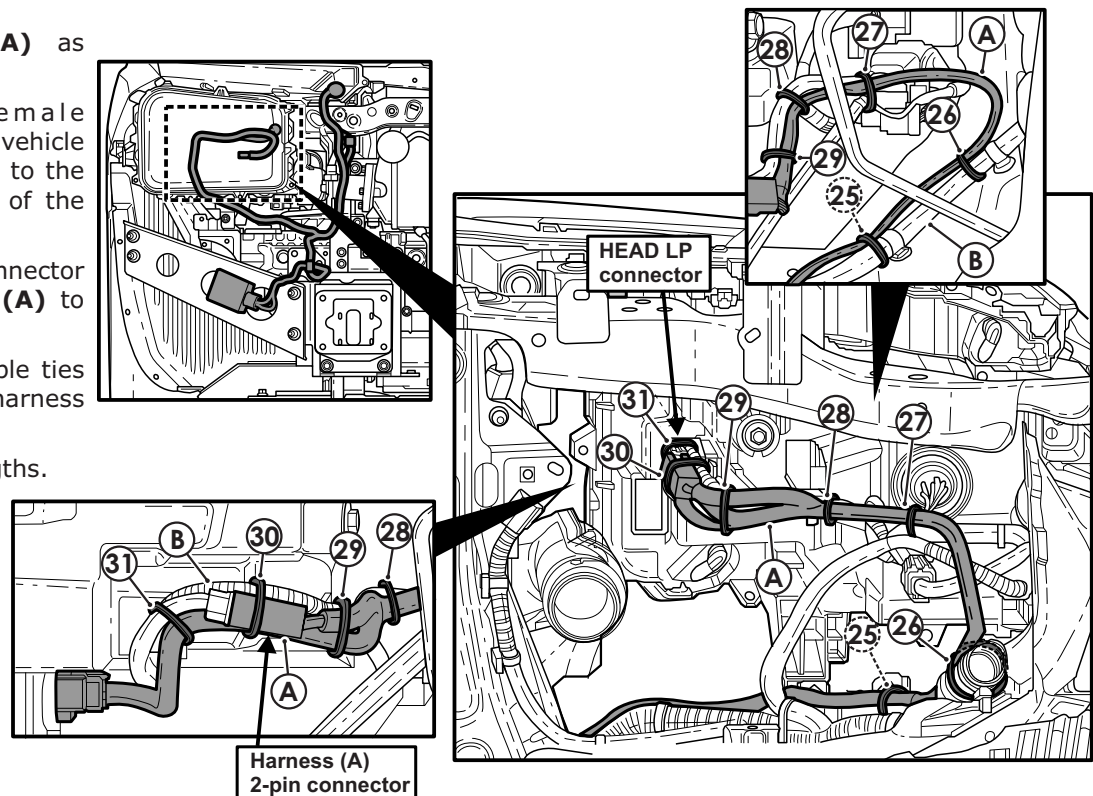

Tools Required: 
Side cutters

– Step 26.5

- Route the Harness **(A)** as shown.
- Disconnect the female connector (8-pin) of the vehicle COMB LP and connect it to the male connector (8-pin) of the harness **(A)**.
- Connect the female connector (8-pin) of the harness **(A)** to the vehicle COMB LP.
- Connect the female connector (12-pin) of the harness **(A)** to the male connector (12-pin) of the vehicle harness **(B)**.
- Secure with 200mm cable ties **(33-36)** and the 150mm cable tie **(2)** to the vehicle harness **(A)** where shown.
- Trim excess cable tie lengths.

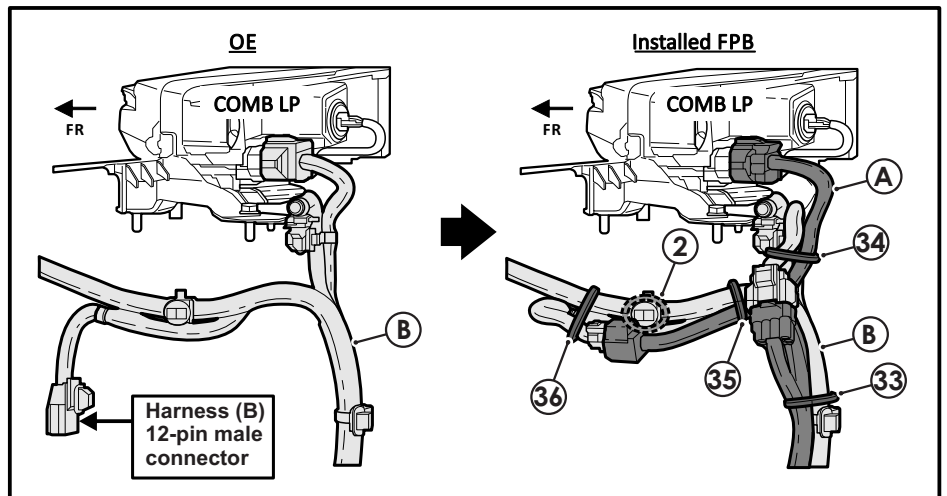

Pass the band cable tie **(2)** through the gap between the connectors and then secure the band to the vehicle harness **(B)**.

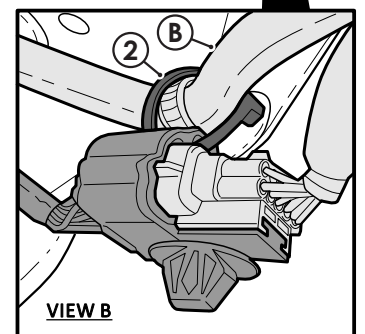
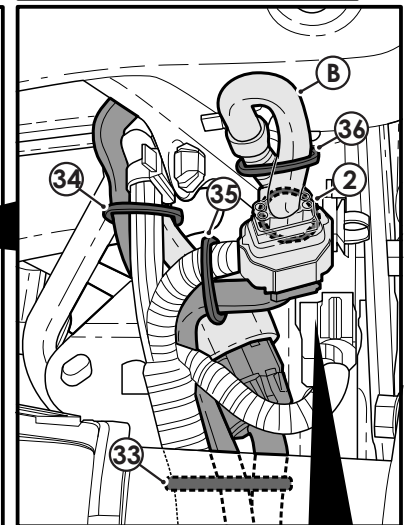
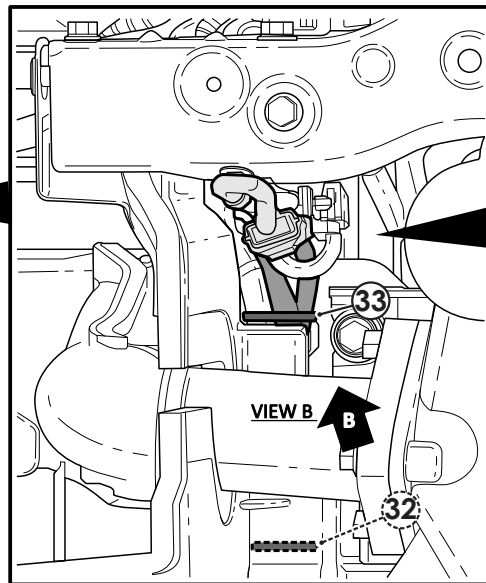
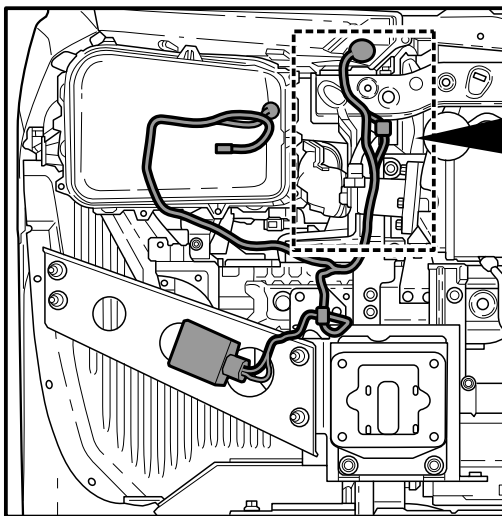
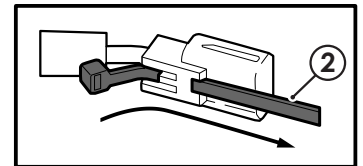

Tools Required: 

Side cutters

– Step 27

If fitting Driving lights, continue with this Step, otherwise proceed to next Step.

- Fit the Driving lights by following the accessory fitting instructions.

Tools Required: 

Refer accessory fitting instructions

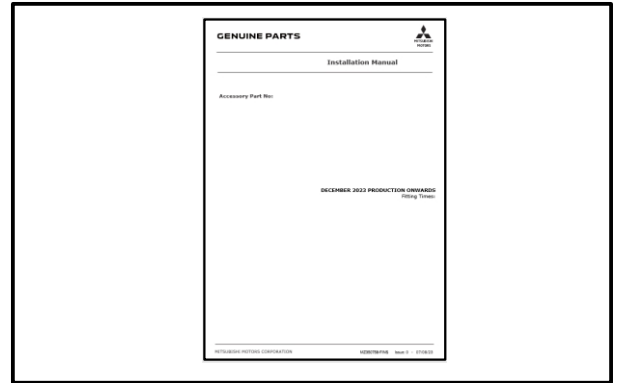

– Step 28

- Refit bumper (1) and then grille (2) to the vehicle (by reversing the removal steps).
- Fit the 4 x M6 x 16 bolts (3) through the grille opening to fasten the Grille Support Brackets to the Grille Frame brackets (4).
- **IF FENDER FLARES FITTED REFER TO APPENDIX 2 STEP 7.**
- Refit cut fender flares (5) by following the reverse of removal steps.
- **Torque to 10 ~ 12Nm – 4 places.** 

Tools Required: 

Torque wrench

10mm Socket

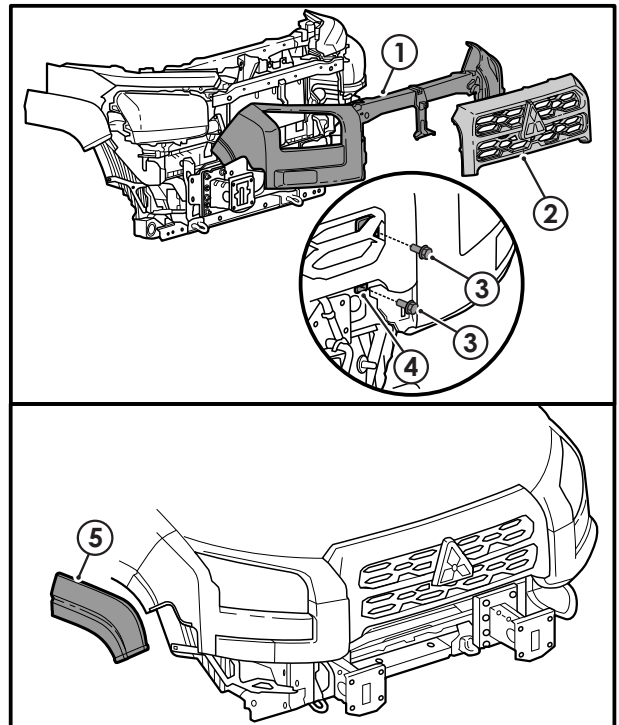

– Step 29

- Prepare the FCM Radar harness. **All Vehicles.**
- Cut tape (A) and remove 2 x OE clips (1 - 2) from vehicle harness.
- Fit the 2x supplied 7 x 12 harness ties (3 - 4), with 135mm and 110mm spacing as shown.

Tools Required: 

Side cutters

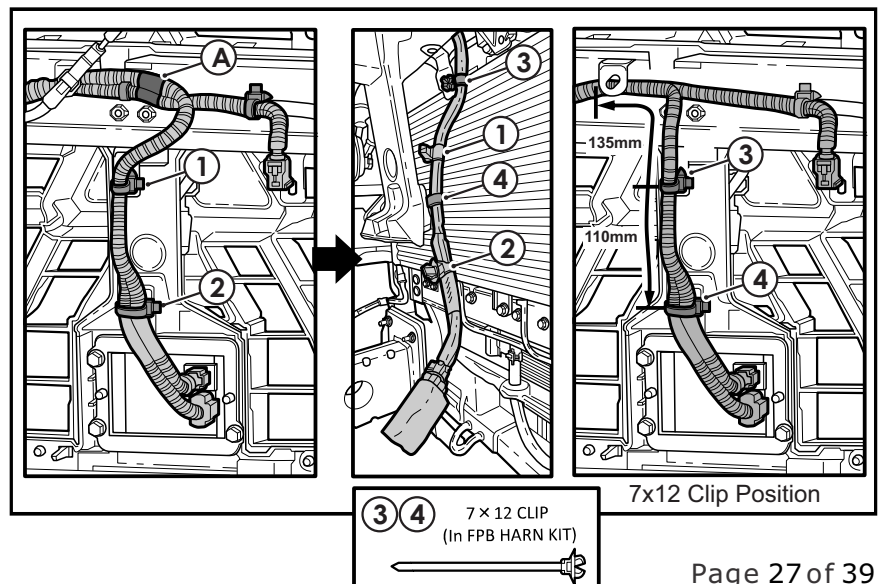

— Step 30

- If applicable, fit the OE camera (1) removed earlier.
- Remove the OE camera & harness clip from its original mounting bracket and retain the fasteners (3).
- Fit the camera (1) to the supplied camera bracket (2) using the OE camera screws (3). Note the camera should be orientated with groove at the bottom. Do not attempt to remove camera harness from camera, as this may damage the camera.
- Using the 2 x supplied M6 x 16mm flanged head bolts (4) and 2 x M6 flanged nuts (5), fix the camera bracket assembly to the top of the radar bracket
- Make sure the camera protrudes through the hole in the top pan and has even gaps.
- Using the supplied cable tie (6), retain the camera harness to the camera bracket. Trim cable tie end.
- **Torque to 10 ~ 12Nm - 2 places.**

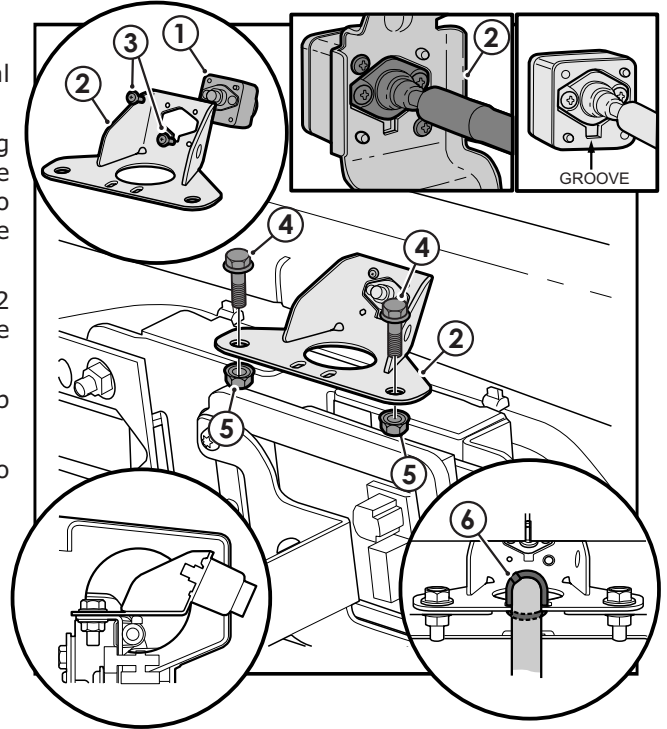

Tools Required: 

Torque wrench

10mm Socket

Phillips head screwdriver



— Step 31

- Fit the OE Radar (1) removed during step 20 and Radar Harness Support Bracket (2) to the Radar Mount (3) on the FPB using the 3 x supplied M6x20mm hexalobular head bolts (4).

- **Torque to 10 ~ 12Nm – 3 places.** 

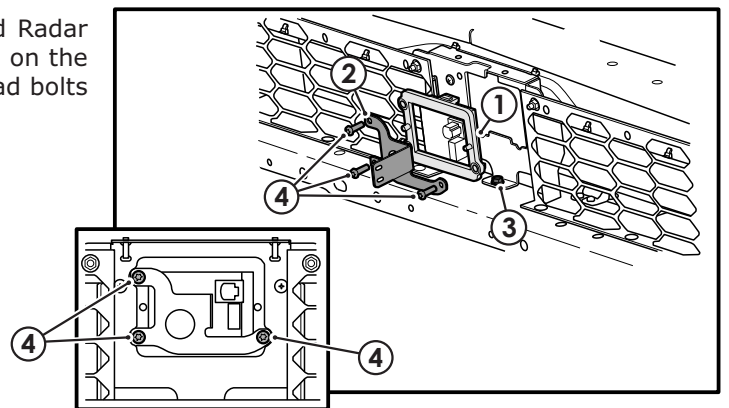

Tools Required: 

Torque wrench

T30 6 spline hexalobular socket

— Step 32

<Type B> VEHICLES

- If applicable, fit the OE Fog Light (1) removed earlier.
- Using the 3 x supplied No.8 x 3/4" Pan head screws (2) fasten the lamp assembly to the lamp housing as shown.
- Insert the wiring harness connector (3) into lamp making sure it is suitably secured into the housing with the retainer clip.
- Repeat for both sides of the vehicle.
- **Torque to 1Nm or just tight.** 

Tools Required: 

Torque wrench

Phillips head screwdriver

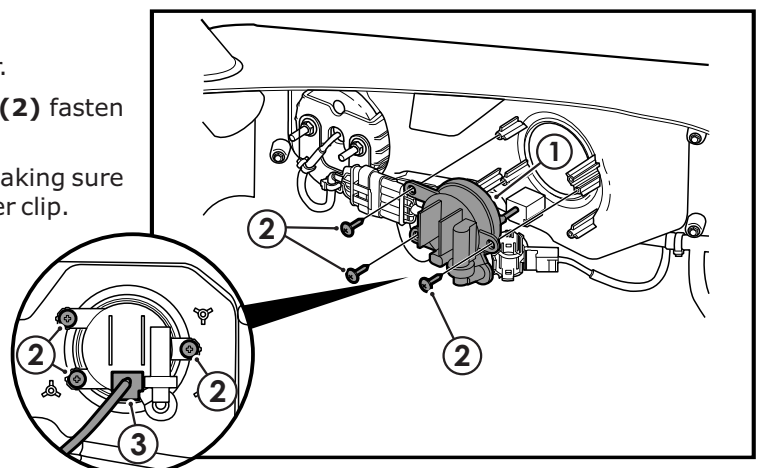

— Step 33

<Type A> VEHICLES

- If applicable, fit the OE Lamp **(1)** removed earlier
- Using the 3x supplied No.8 x 3/4" Pan head screws **(2)** fasten the lamp assembly to the lamp housing as shown.
- If vehicle is fitted with DRL only lamp, there is no need to connect harness to lamp as DRL function is transferred to outer combination lamp of FPB.
- Remove the taped back harness connector **(3)** and insert into lamp making sure it is suitably secured into the housing with the retainer clip
- If vehicle is equipped with combination Fog/DRL or DRL lamps, fit the blanking plug **(4)** supplied with wiring harness kit to lower DRL connector
- Repeat for both sides of the vehicle.
- **Torque to 1Nm or just tight – 3 places.** ⚠

Tools Required: 

Torque wrench

Phillips head screwdriver

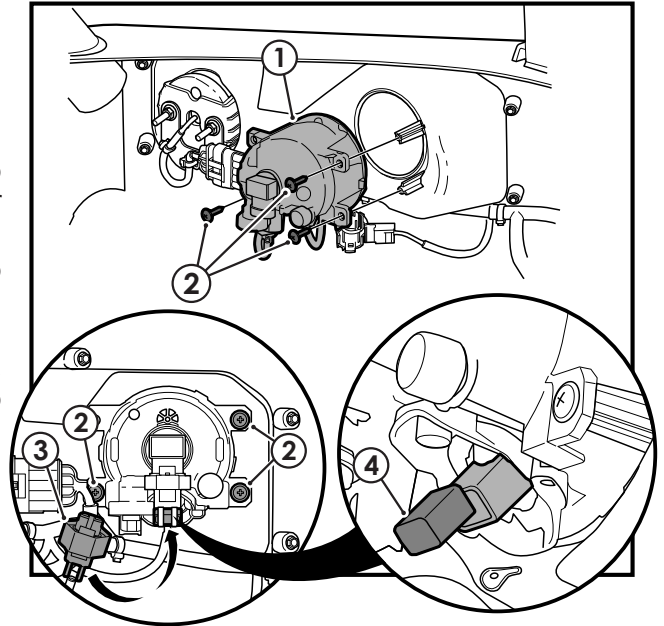

— Step 34

- Fit the OE Parking Sensors **(1)** removed earlier.
- Fit sensor **(1)** and O-ring **(2)** into the sensor bezel as shown.
- Press the sensor back firmly while holding the bezel outer making sure the barbs on the sensor clip into the housing.
- Fit the connector from the FPB wiring harness into the back of the parking sensor.
- **If fitting winch kit MZ350761 – refer to winch fitting instructions.**

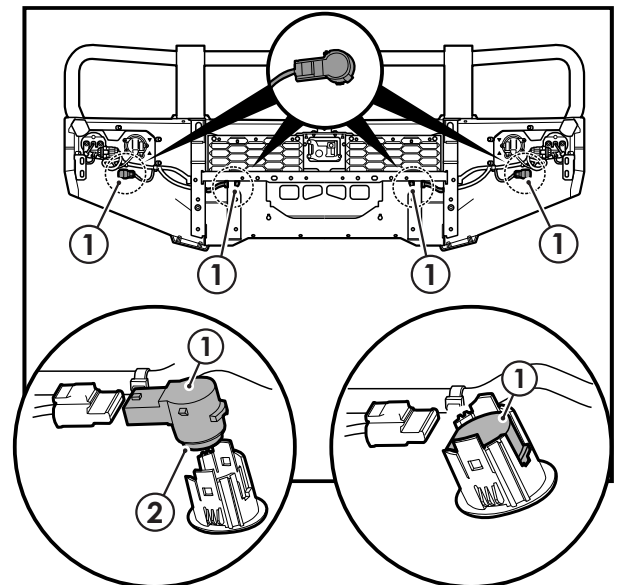

– Step 35

- Fit 1 x 5mm spacer (1) over the weld studs on each side.
- With assistance, offer the FPB (2) to the crash box (3) and loosely secure with the 4 x Dog Bone washer plates (4) and 8 x M10 flanged nuts (5).
- Tighten the nuts (5) until the FPB (2) is sitting flush with the crash box mount face. Don't over-tighten, must allow vertical and lateral FPB adjustment.

Note

Two person lift. Request assistance when lifting. Ensure wiring harness is not trapped in between FPB and vehicle mating parts when installing.

Tools Required:



Ratchet

14mm deep socket

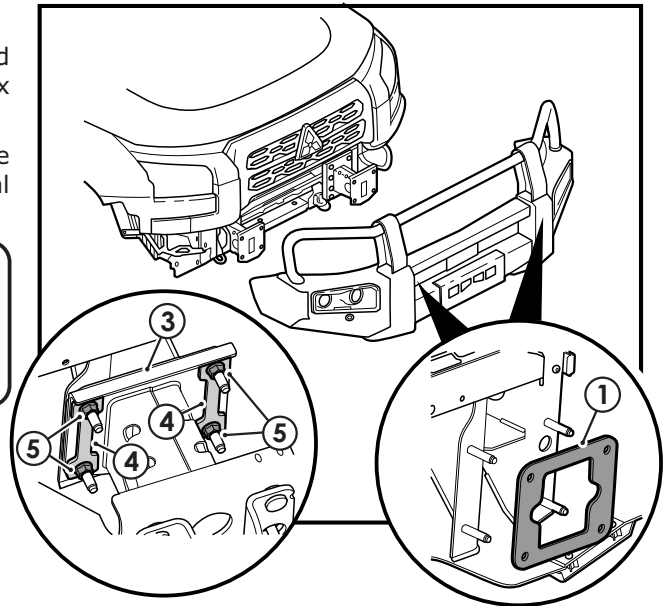

– Step 36

- Adjust the FPB across car until central by measuring from fixed point on vehicle bumper to FPB (1).

Note

Apply masking tape or similar to steel ruler to ensure no damage to paint.

Tools Required:



Steel Ruler

Masking tape

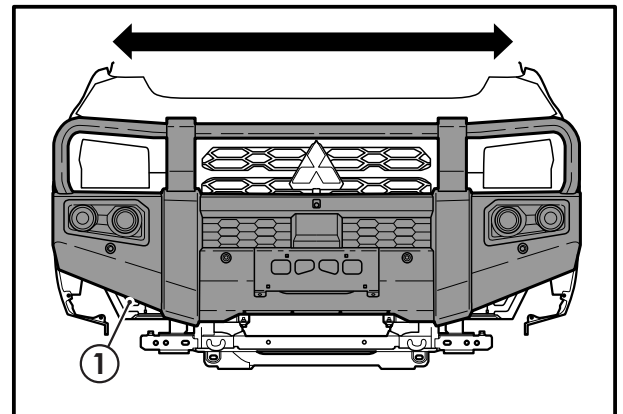

– Step 37

Adjust the FPB in height until the following conditions are met:

- Wheel arch alignment and gap measured from vehicle bumper to FPB conforms to values shown in step 38.
- Tighten 2x diagonal flanged nuts (1) on each side of the crash box front flange.
- Confirm gap between upper pan and 3 diamond grille badge is not less than 34mm to ensure position of FPB upper hoop does not obstruct windscreen mounted camera.

Tools Required:



Steel Ruler

Ratchet

14mm deep socket

Masking tape

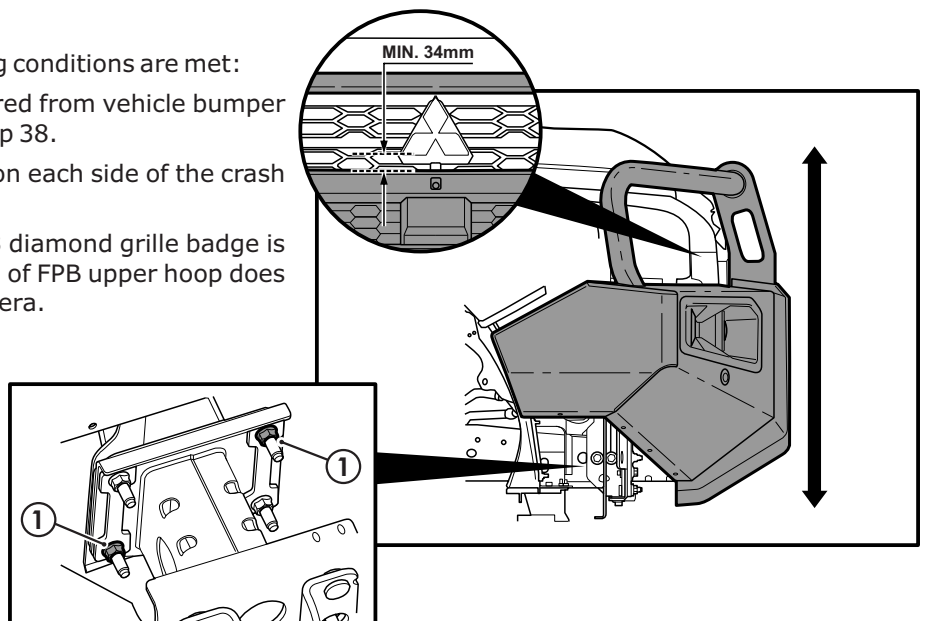

Step 38

Confirm FPB gap/Fitment.

- Gap between fender flare cap and FPB **(1)** is greater than 20mm.
- Confirm gap between pinch weld and FPB is greater than 25mm between uprights **(2)**.

Tools Required: 

Steel Ruler

Masking tape

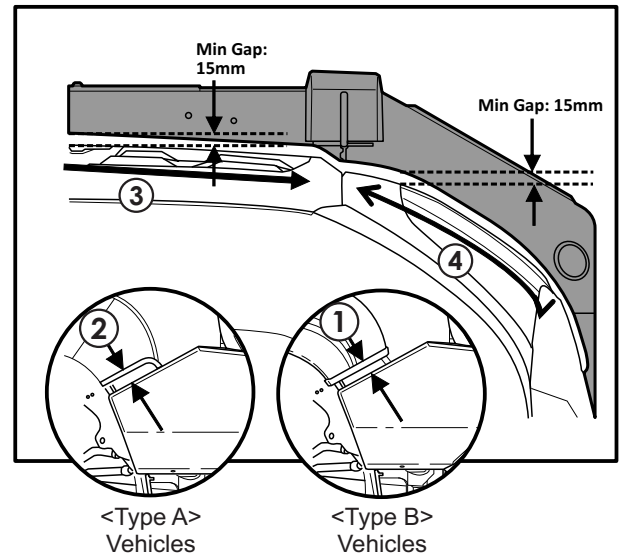

Step 39

If gap condition was not achieved in step 37 or 38, continue with this step, otherwise proceed to step 40.

- With assistance, carefully remove FPB by removing flanged nuts and washer plates assembled in step 35.
- If gap measured was too small, add 2.5mm shim to FPB weld studs.
- If gap measured was too big, remove 5mm shim and replace with 2.5mm shim to FPB weld studs.

Repeat Steps 35 to 38 for FPB fitment.

Note

Important Max shim condition: 10mm.
Min shim condition : 0mm.

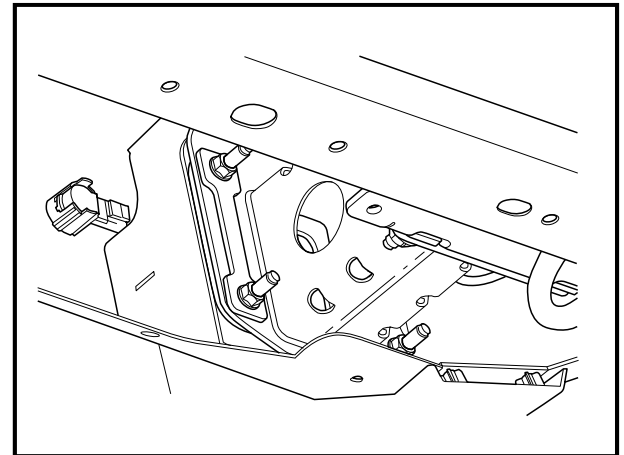

Step 40

- Loosely attach RH front wing brace **(1)** between wing brace plate/winch cradle **(2)** and FPB wing attachment bracket **(3)** using 4 x M10 x 35 flanged bolt **(4)**, 4 x M10 x 4mm x25mm OD thick washer **(5)** and 4 x M10 flanged nut **(6)**.
- Push wing brace upwards when tightening bolts to maximise gap to undercovers.
- Repeat for LH wing brace.

Note: Vehicle not shown in image.

Note

Ensure correct orientation of wing brace and fasteners as shown.

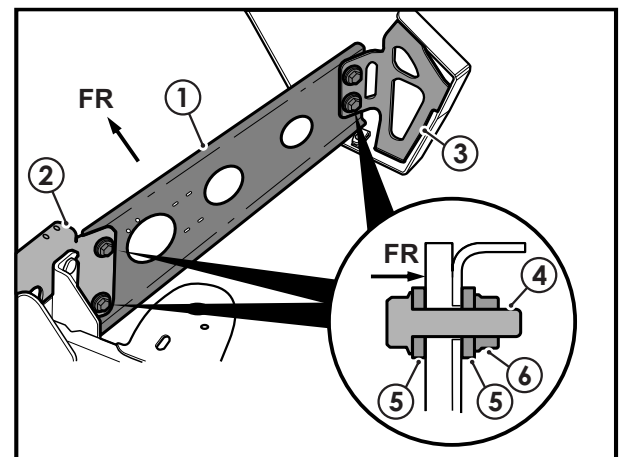

Tools Required: 

NA - Hand tighten only

– Step 41

- **Torque all M10 flanged head bolts and nuts to 70Nm - 75Nm in the following sequence:**

1. Crash box to FPB (four places per side).
2. Winch cradle/ wing attachment bracket to front wing brace (two places per side).
3. Wing brace to wing brace bracket (two places per side).

Note

Do not use a rattle gun or impact driver.

Tools Required:

- 13mm or 14mm deep socket
- 13mm or 14mm spanner or socket
- Torque wrench

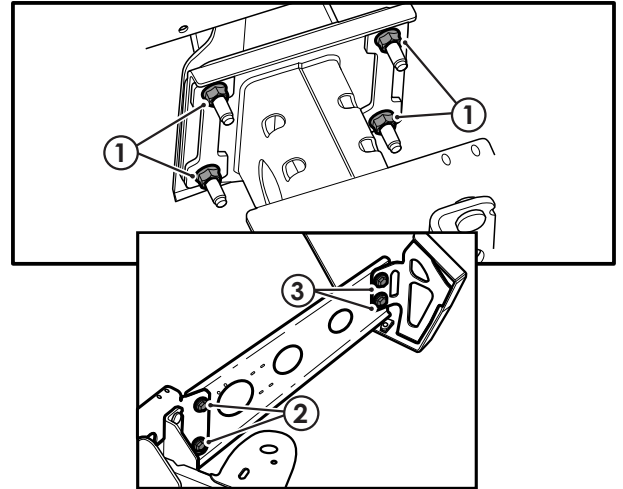

– Step 42

- Connect the LHS vehicle side harness to the LHS FPB Harness. **(1)**.
- Connect the RHS vehicle side harness to the RHS FPB Harness **(2)**.
- **Confirm the vehicle side harness and FPB harness colour patches match (3).**
- LHS – RED
- RHS - YELLOW
- **If fitting winch kit MZ350761 – refer to winch fitting instructions.**

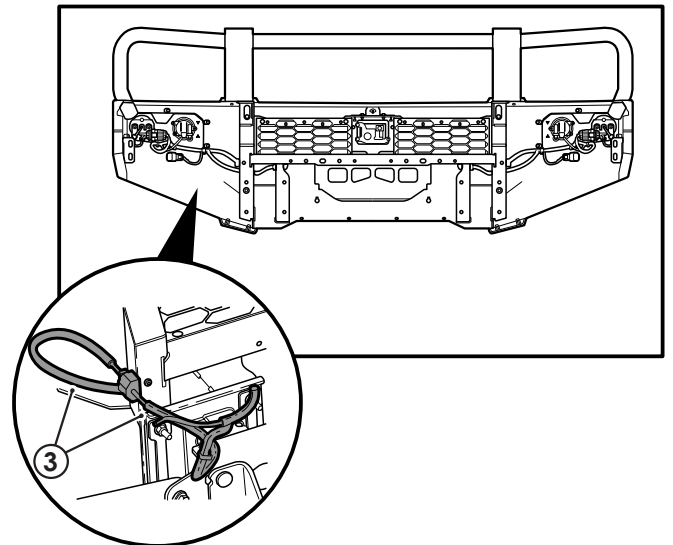

— Step 43 —

- If fitted to base vehicle, refit front camera harness to vehicle harness as shown.
- Fit the edge clip to the grille bracket as shown **(1)**.
- Route the front camera harness as shown.
- Secure the vehicle harness beside to the vehicle clip position with a cable tie **(37 - 38)**.
- Trim excess cable tie lengths.

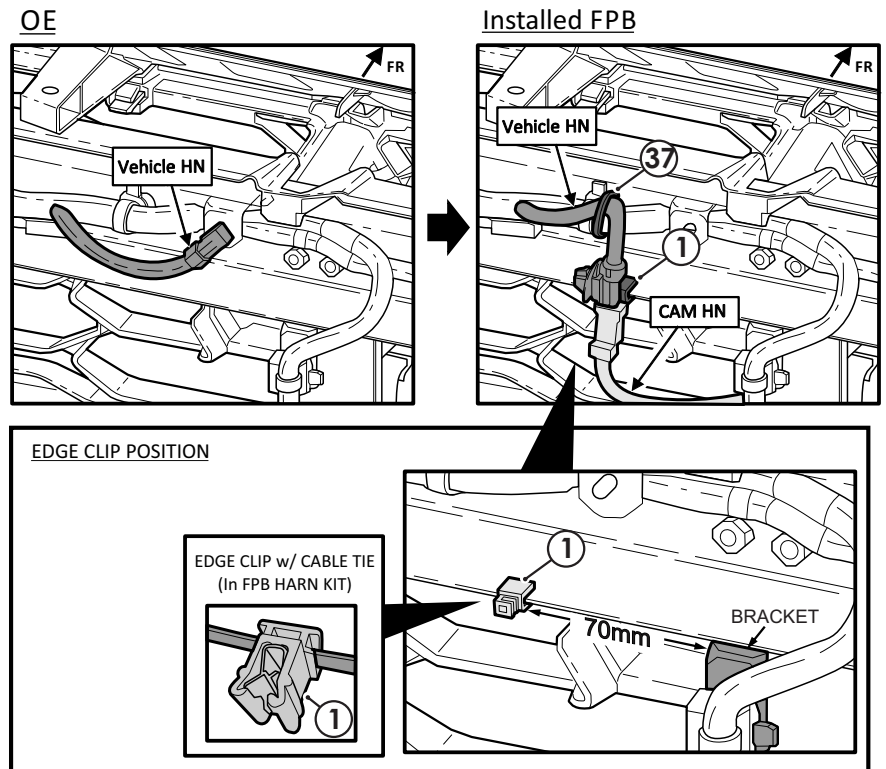

<Type A Vehicles>

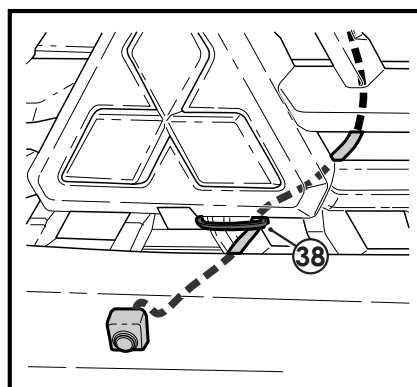

<Type B Vehicles>

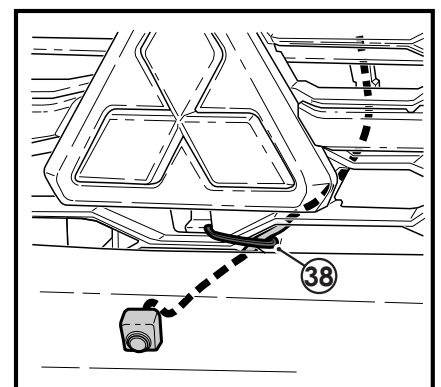

Tools Required: 

Side cutters

— Step 44 —

- Connect FCM Radar harness to the radar as shown.
- Route the harness as shown.
- Secure the RADAR harness to the vehicle harness and RADAR bracket with a cable tie (**40 - 42**).
- Trim excess cable tie lengths.

Tools Required: 
Side cutters

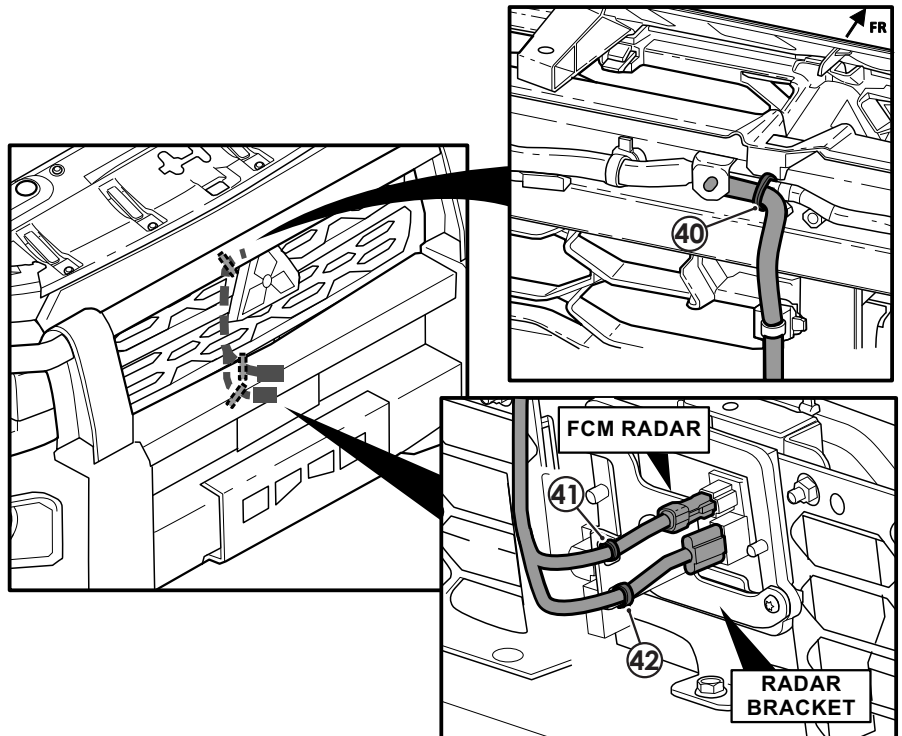

— Step 45 —

- Using the foam pad (**3**) supplied in the vehicle side harness kit, Wrap together the two side radar units removed in step 20.
- Connect the two radar harness connectors on the FPB body harness to the side radars.
- Fasten the side radars to the RHS wing support using 2 x 300mm cable ties (**1**) & (**2**).
- Secure side radar harness with 200mm cable tie (**21**).
- Trim the excess cable tie length with side cutters.

Tools Required: 
Side cutters

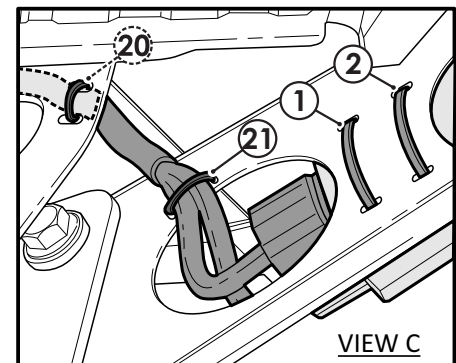
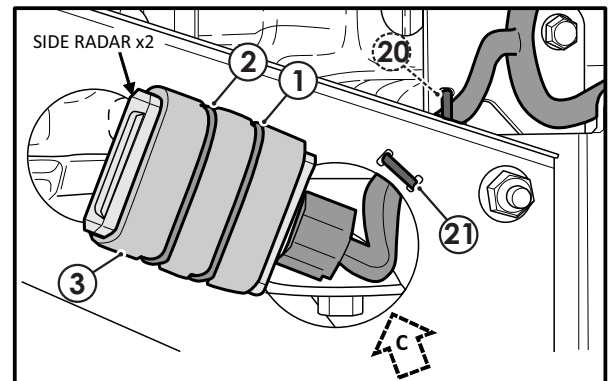

— Step 46 —

If installing driving light:

- Connect accessory driving light, adjust angle and torque to specification.

— Step 47 —

Note

Reconnect negative battery terminal.

- Check for correct functionality of the FPB Indicator and Position lamp system :

- Turn vehicle ignition ON. If vehicle is equipped with DRL's and they are ON, FPB Lamp DRL's should also turn ON.

NOTE: Vehicle DRL's will only turn ON when headlamp switch is set to auto, position lamps and headlamps are off with vehicle in direct sunlight.

- Turn vehicle position lamps ON. FPB DRL's should DIM.

- Turn LH vehicle indicator ON. LH FPB Indicator should also turn ON (flash) and LH FPB DRL should DIM.

- Turn RH vehicle indicator ON. RH FPB Indicator should also turn ON (flash) and RH FPB DRL should DIM.

- Turn vehicle hazards ON. Both FPB indicators should turn ON (flash) and both FPB DRL's should DIM .

- Turn vehicle hazards & indicators off and turn OFF vehicle. All FPB Lamps should turn off.

- Confirm operation of front parking sensors (as shown below).

- Confirm operation of fog lamps and adjust lamp angle (if fitted)

Note

Refer to the vehicle's workshop manual when adjusting aiming of fog lamps. Position of lamp aiming screw may vary depending on model, aiming screw can be accessed from rear of FPB.

Tools Required: 

Phillips head screwdriver

10mm socket

■ FUNCTION CHECK TEST

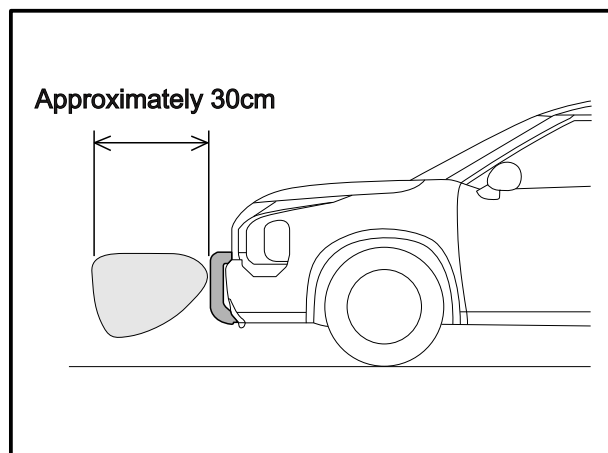

1. Start the engine.

2. Using the box, etc. which packed the FPB, make sure that that continuous buzzer sounds approximately 30cm from the sensor.

- **Note: the functionality of the parking sensors may vary slightly in their new position.**

– Step 48

- Attach the Side undercover lower mount bracket (1) to the vehicle chassis wing brace (2) using the M8 x 20 pan head screw (3) and M8 flanged nut (4) inside the chassis frame (1 place per side).
- Attach M6 U-nut (5) to side undercover lower mount bracket (1) (1 place per side).
- **Torque to 25 ~ 30Nm – 2 places.** ⚠

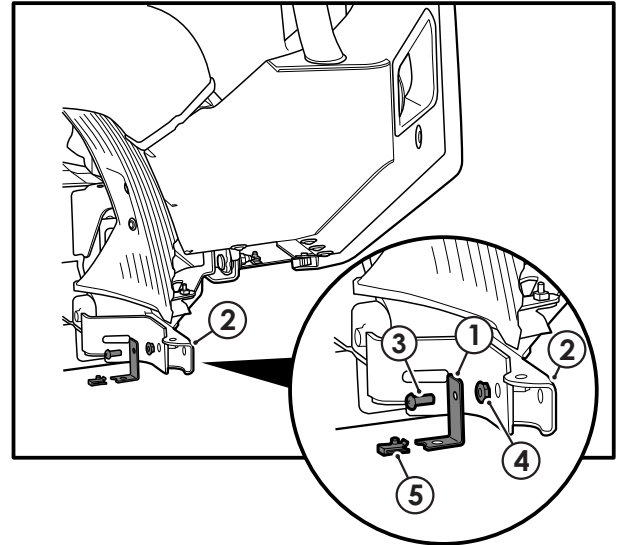

Tools Required:

Torque Wrench

T-40 Hexalobular socket bit

12mm spanner

– Step 49

- Attach M6 U-nut (1) to plastic RH (2) and LH (3) splash shields (5 per side).

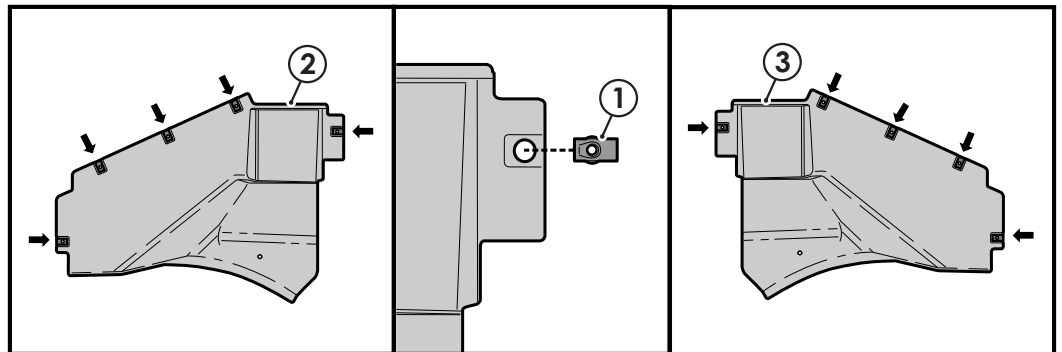

– Step 50

- Position RH side splash shield (1) in place inside the FPB wing and loosely secure to FPB wing and side undercover lower mount bracket with M6x20mm hexalobular pan head bolts (2) and M6x22mm OD washer (3) in 5 places.
- Repeat for LH side splash shield.

Note: Fasteners are torqued at step 52.

Tools Required:

T-30 Hexalobular socket bit

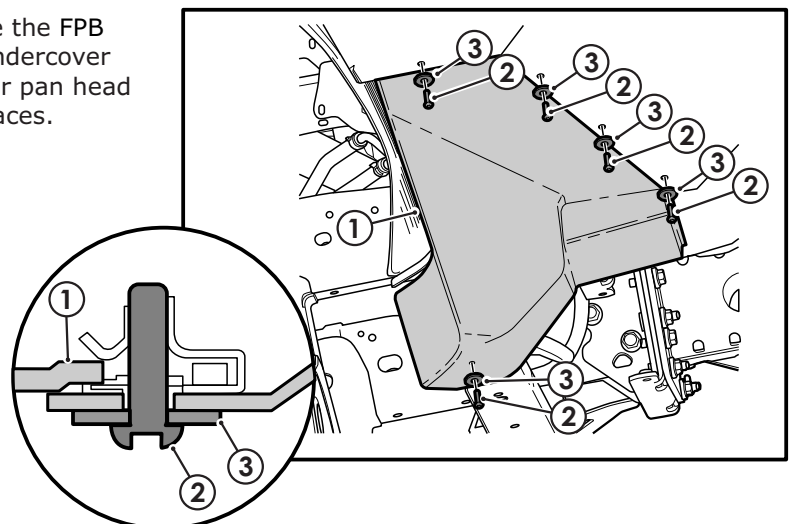

– Step 51

- Attach M6 U-nuts **(1)** to the FPB lower pan edge (4 places).

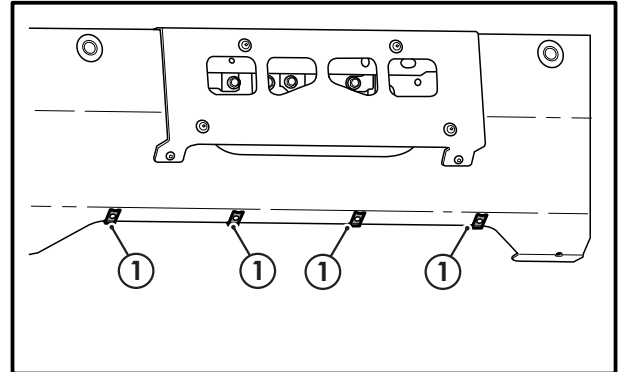

– Step 52

- **If fitting winch kit MZ350761 – refer to winch fitting instructions.**
- Re-Fit the OE undercovers making sure the front two bolts are not installed **(1)**.
- Loosely secure FPB centre undercover **(2)** using 6 x M6x20mm hexalobular pan head bolts **(3)** and 6 x M6x22mm OD washer **(4)**.
- Loosely fit the 2 x M8x25mm hexalobular pan head bolts **(5)** and 2 x M8x24mm OD washer **(6)** at the rear edge of the centre undercover, sandwiching the front edge of the skid plate.
- **Torque all M6 to 5 ~ 7Nm – 16 places. ⚠**
- **Torque all M8 to 25 ~ 30Nm – 2 places. ⚠**
- **Torque OE undercover fasteners to specification. ⚠**

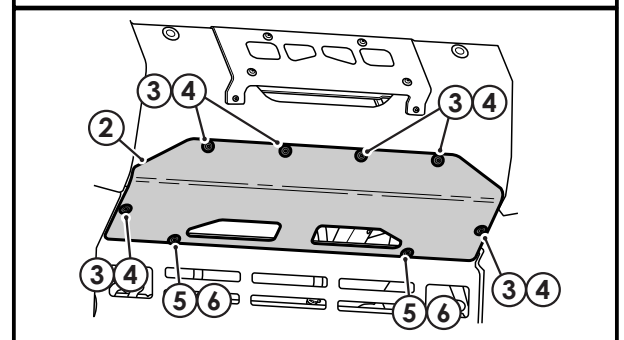
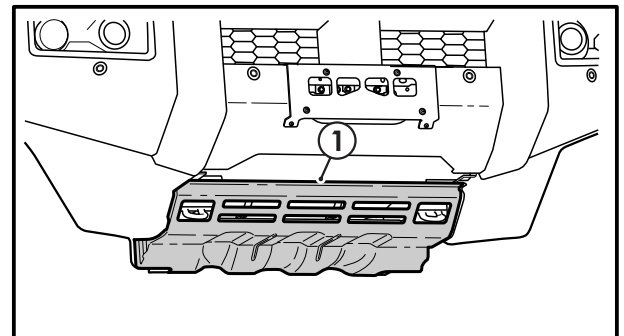



Tools Required: 

Torque wrench

T30 & T40 Hexalobular socket bit

14mm Socket

INSTALLATION CHECK LIST	
Dealer Name:	Dealer Code
Model:	Stock No:
Order Date:	Order No:
Required By:	Vin No:
Vehicle Damage Check:	
FPB CHECKLIST	
1. Ensure correct spacing from FPB ar to bumper	<input type="checkbox"/>
2. Fog Lamps Operational (if fitted)	<input type="checkbox"/>
3. Front Position Lamps Operational	<input type="checkbox"/>
4. Right/Left indicators (front and rear)	<input type="checkbox"/>
5. Parking Sensors Operational	<input type="checkbox"/>
6. Confirm Front Camera & Multi Around Monitor (if applicable)	<input type="checkbox"/>
7. Radar Calibration Complete (refer to FCM-ECM Alignment procedure in vehicle's workshop manual).	<input type="checkbox"/>
8. Ensure FCTA function is permanently disabled in M.U.T.-III.	<input type="checkbox"/>
9. Confirm all bolts are torqued as specified.	<input type="checkbox"/>
10. Batch No.	<input type="checkbox"/>
Record applicable batch number here:	
<div style="border: 1px solid black; padding: 5px; margin-bottom: 10px;">  MITSUBISHI MOTORS TRITON (12/2023 ON) <div style="display: flex; justify-content: space-between; align-items: center;"> <div style="border: 1px solid black; padding: 2px;">MZ350757 MZ350758</div> <div style="border: 1px solid black; padding: 2px;">BATCH NO. <input style="width: 50px;" type="text"/></div> </div> <ul style="list-style-type: none"> THIS PRODUCT OR ITS FIXING MUST NOT BE MODIFIED. NO ACCESSORY OR FITMENT SHALL PROJECT FORWARD OF THIS PRODUCT'S FORWARD PROFILE. DO NOT USE THIS PRODUCT IN ANY OTHER MOTOR VEHICLE FOR WHICH IT IS NOT DESIGNED. </div>	<div style="border: 1px solid black; padding: 5px; margin-bottom: 10px;">  MITSUBISHI MOTORS TRITON (12/2023 ON) <div style="display: flex; justify-content: space-between; align-items: center;"> <div style="border: 1px solid black; padding: 2px;">MZ350759 MZ350760</div> <div style="border: 1px solid black; padding: 2px;">BATCH NO. <input style="width: 50px;" type="text"/></div> </div> <ul style="list-style-type: none"> THIS PRODUCT OR ITS FIXING MUST NOT BE MODIFIED. NO ACCESSORY OR FITMENT SHALL PROJECT FORWARD OF THIS PRODUCT'S FORWARD PROFILE. DO NOT USE THIS PRODUCT IN ANY OTHER MOTOR VEHICLE FOR WHICH IT IS NOT DESIGNED. </div>
Comments:	
Fitted By:	
Checked By:	

APPENDIX 1 <TYPE A VEHICLES>

BUMPER CUT
GRILLE CUT

(Page 2-3)
(Page 4)

– Step 1

Front Bumper Cut <TYPE A> Templates.

- Confirm correct FPB and vehicle as per ID label **(1)**.
- Remove number plate **(2)** and keep for re-fitting to FPB.

Tools Required:

Ratchet

10mm socket



①

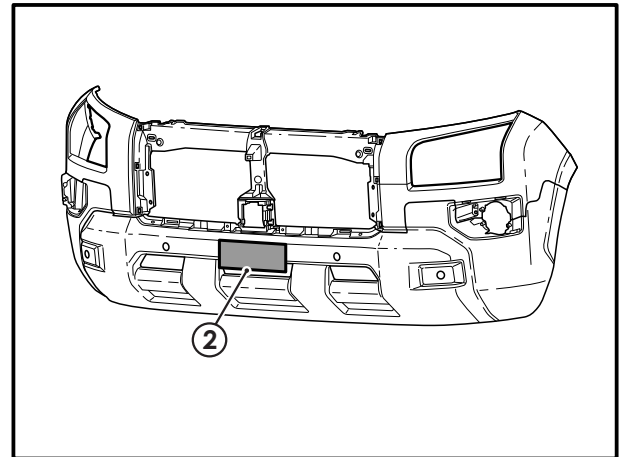

– Step 2

Front Bumper Cut <TYPE A> Templates.

- Confirm templates are to scale by checking 50mm scale marker with steel ruler.
- Cut LH outboard template **(1)** and adhere to bumper as per the instructions on cut template.
- Check template is parallel to bumper join **(2)**.
- Cut the LH inboard template **(3)** and adhere to bumper as per the instructions on cut template
- Mark the outer cut line on the bumper with a paint pen or permanent marker
- Mark the inner cut line on the bumper with a paint pen or permanent marker
- From the lamp pocket surface **(4)** mark a horizontal line 95mm forwards **(5)**.
- From the clip slot **(6)** measure downwards 22mm and mark a line forwards **(7)**.
- Mark cut lines **(8)** & **(9)**.

- Repeat for RHS.

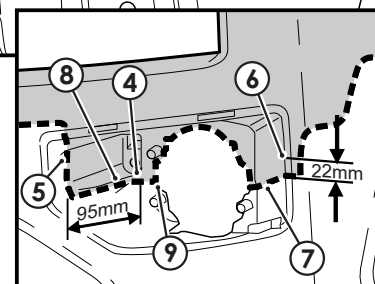
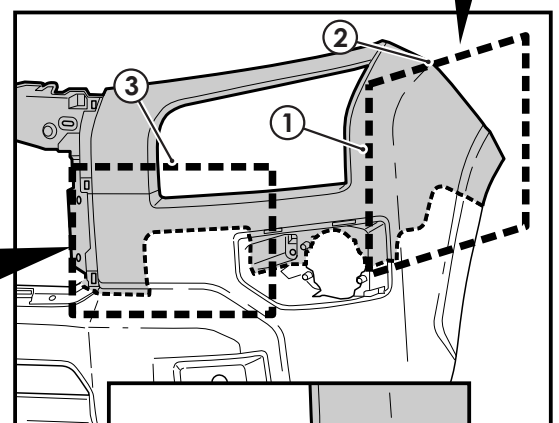
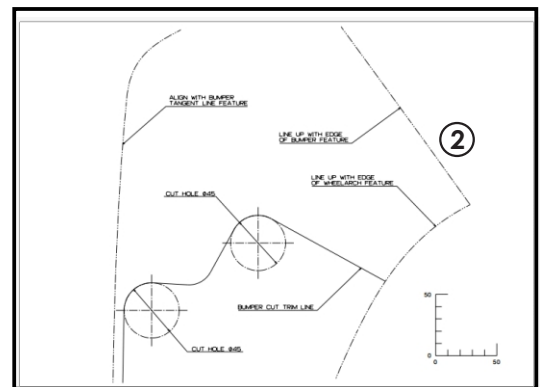
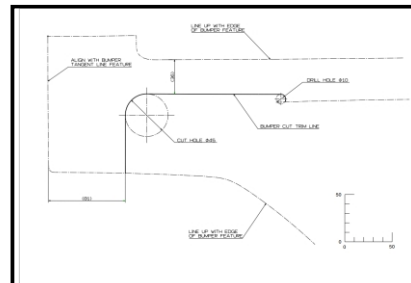

Tools Required:

Marker pen

Masking tape

Steel ruler

Scissors

Ø45 Hole Saw

– Step 3

- Using a ruler, Mark line **(1)** 9.0mm from the bumper edge detail as shown.
- Where the bumper transitions at point **(2)** draw a straight line to the corner of the two surfaces **(3)**.
- **Repeat for RHS.**

Tools Required: 

Marker pen
Masking tape
Steel ruler

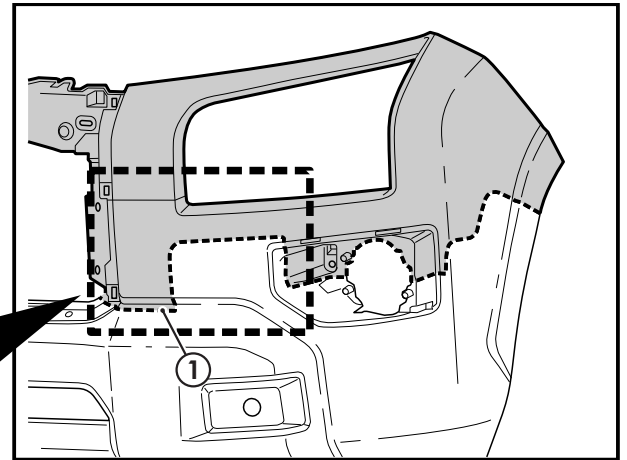
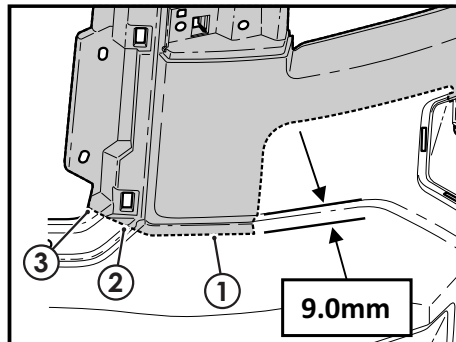

– Step 4

- Mark the centre support cut line at the lower radius tangent edge as shown.

Tools Required: 

Marker pen

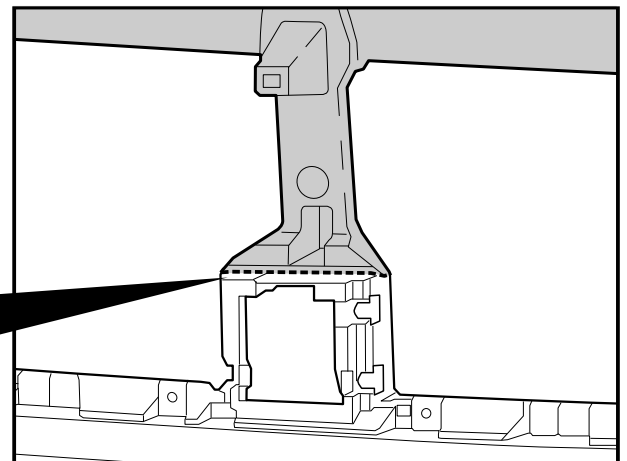
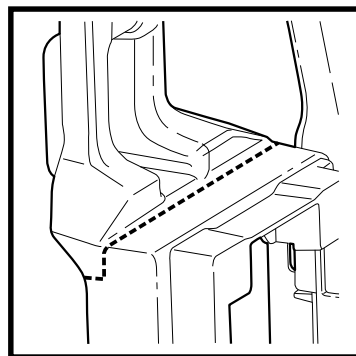

– Step 5

Front Bumper cutting:

- With care, cut the bumper with multi tool.
- Deburr cut edges and wipe upper bumper **(1)** clean with a soft clean rag.
- Discard/dispose of lower section **(2)**.

Tools Required: 

Multi tool
De-burring tool
Clean rag

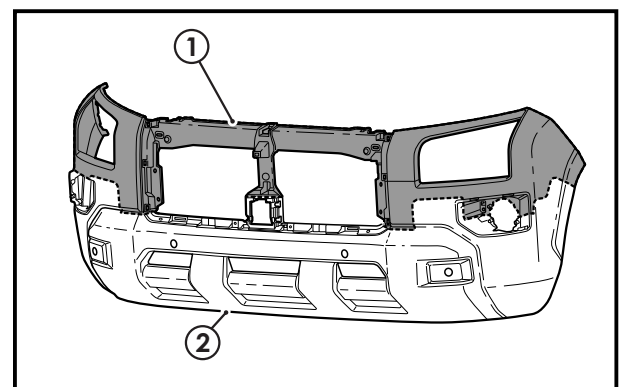

– Step 6

- Fit pinch weld **(1)** to bumper **(2)** as shown. Always start from outboard edge and work towards the centre.
- Trim the pinch weld length if required using side cutters.
- Once fitment path is confirmed, carefully remove pinch weld **(1)** and apply super glue into the pinch weld channel.
- Carefully re-apply pinch weld **(1)** to bumper **(2)** and secure in position until glue is set from bumper.
- Repeat for RHS.

Tools Required: 

Super glue
Side cutters

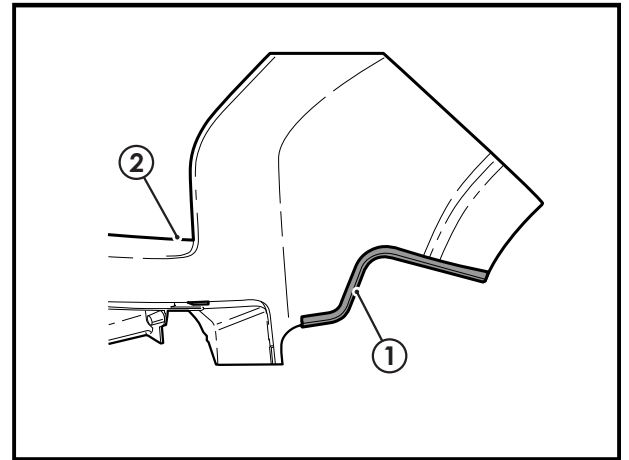

– Step 7

Grille Cut – <Type A> Grille

- Mark point 84mm down from the bottom edge of the grille clip boss **(1)**.
- Mark points on the grille as shown using paint pen or permanent marker **(2)**.
- Cut along marked line.
- Discard lower portion **(3)**.
- Deburr cut edge.

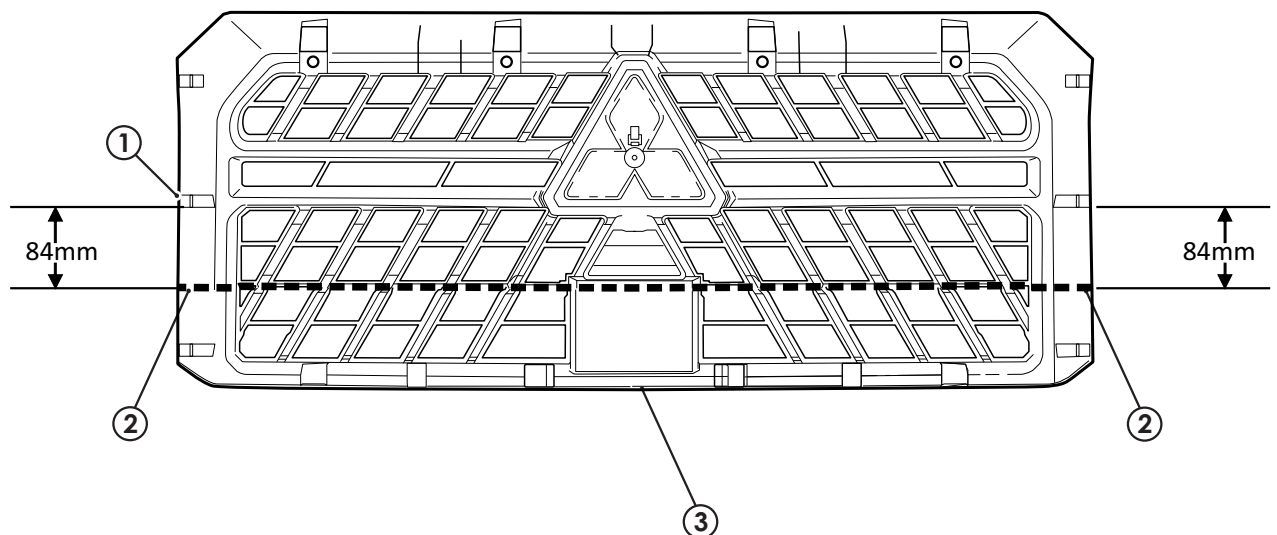

Tools Required: 

Paint Pen
Multi tool
De-burrer
Ruler

APPENDIX 2 <TYPE B> VEHICLES

BUMPER CUT	(Page 2 - 3)
GRILLE CUT	(Page 4)
FENDER FLARE CUT (IF FITTED)	(Page 5)

– Step 1

Front Bumper <Type B> Vehicle Templates.

- Confirm correct FPB and vehicle as per ID label **(1)**.
- Remove number plate **(2)** and keep for re-fitting to FPB.

Tools Required:

Ratchet

10mm socket



(1)

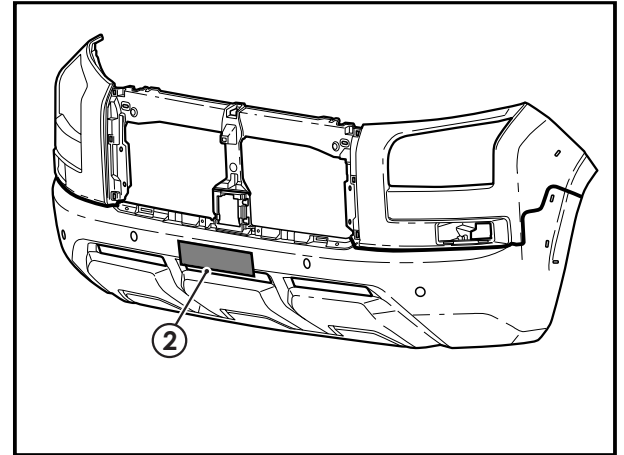

– Step 2

Front Bumper Cut <Type B> Vehicle Templates.

- Confirm template scale by checking 50mm scale marker with steel rule.
- Cut LH outboard template **(1)** and adhere to bumper as per the instructions on cut template.
- Check template is parallel to bumper join **(2)**.
- Mark the outer cut line on the bumper with a paint pen or permanent marker
- Apply masking tape to the surface under the chrome lamp garnish **(3)**.
- Mark the cut line **(4)** 5.0mm from the chrome bezel onto bumper between the inner edge of the bezel and outer cut template line.
- Mark a cut line from corner **(6)** to the end of line **(4)** at 45degrees.
- **Repeat for RHS.**

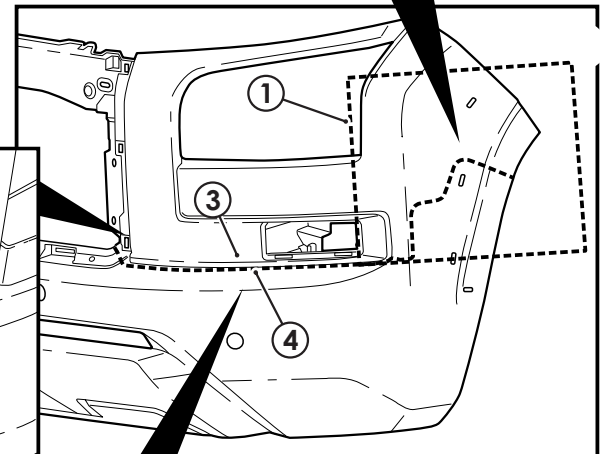
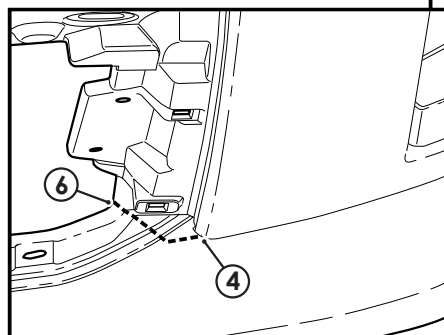
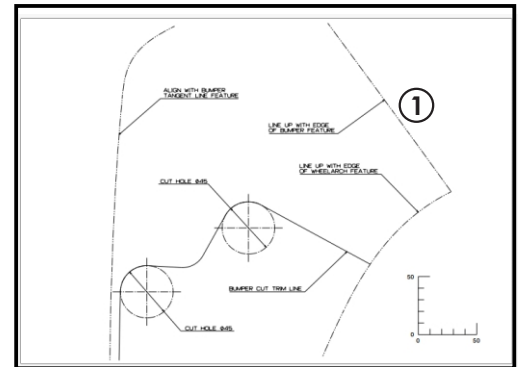

Tools Required:

Marker pen

Masking tape

Steel ruler

Scissors

Ø45 Hole Saw

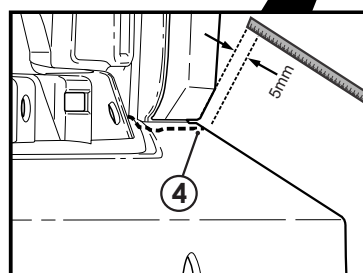

– Step 3

- Mark the centre support cut line at the lower radius tangent edge as shown.

Tools Required: 

Marker pen

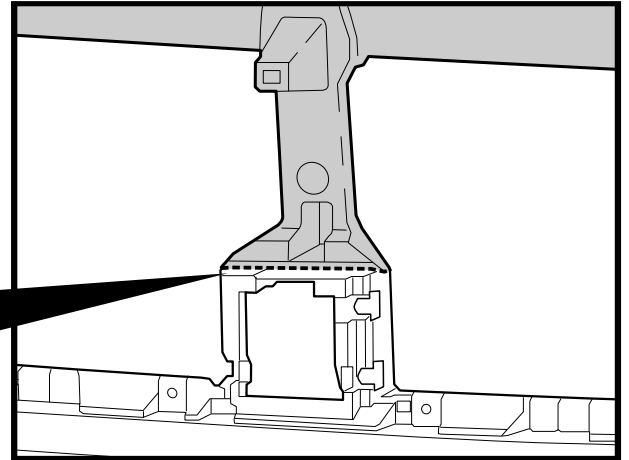
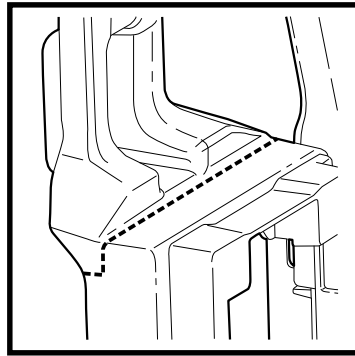

– Step 4

Front Bumper cutting:

- With care, cut the bumper with multi tool.
- Deburr cut edges and wipe upper bumper (1) clean with a soft clean rag.
- Discard/dispose of lower section (2).

Note

- Take Care when cutting.
- Use correct PPE to protect eyes, ears and hands.

Tools Required: 

Multi tool

Deburring tool

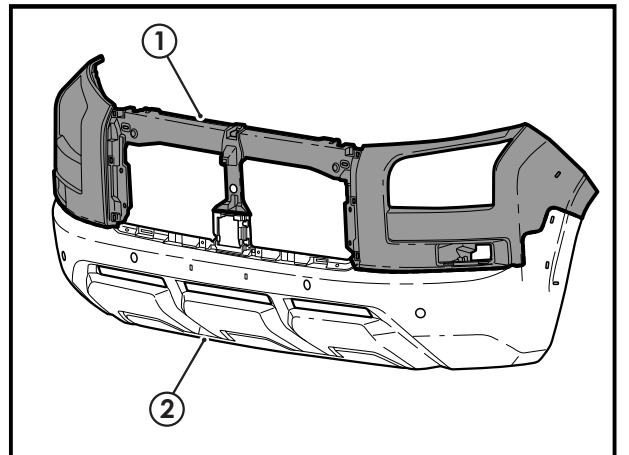

– Step 5

- Fit pinch weld (1) to bumper (2) as shown. Always start from outboard edge and work towards the centre.
- Trim the pinch weld length if required using side cutters
- Once fitment path is confirmed, carefully remove pinch weld (1) and apply super glue into the pinch weld channel.
- Carefully re-apply pinch weld (1) to bumper (2) and secure in position until glue is set from bumper.
- Repeat for RHS.

Tools Required: 

Side cutter

Super glue

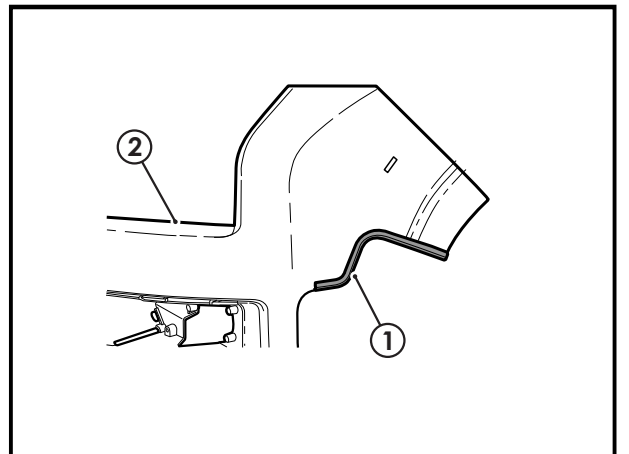

– Step 6

Grille Cut – <Type B> Vehicle Grille

- Mark point 90mm up from the bottom edge of the grille outer **(1)**.
- Mark points on the inner grille below lower edge of crossbar feature in grille **(2)**.
- Cut along marked line.
- Discard lower portion **(3)**.
- Deburr cut edge.

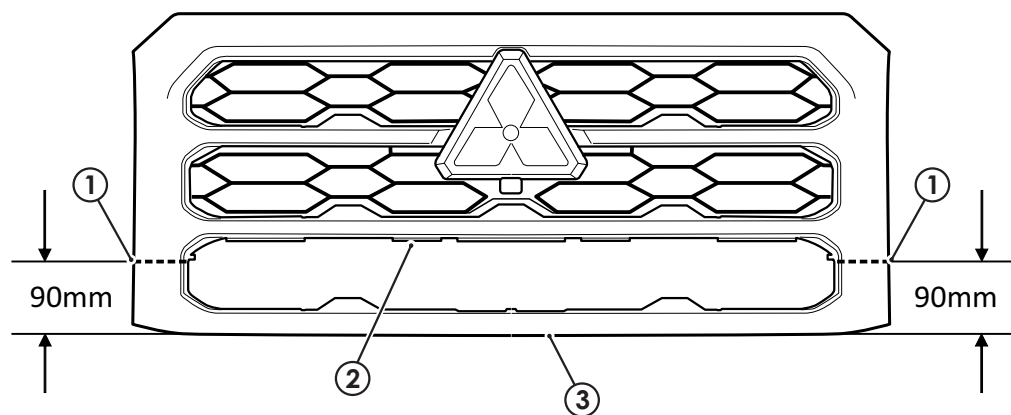

Tools Required:

- Marker pen
- Multi tool
- Deburrer
- Steel rule

– Step 7

IF OE FENDER FLARES FITTED – <Type B> Vehicles

- Offer the Fender Flare (1) up to the fender and cut bumper.
- Using the cut bumper as a guide, mark a line (2) 3.0mm from the cut bumper as shown.
- Remove the fender flare from the front fender
- Using a multi tool, trim the flare along the marked line (2)
- Deburr fender flare cut edge
- Offer the RH flare cap (3) up to the cut flare and using a power drill, drill a 2.0mm hole through the fender flare cap and the flair inner support (4).

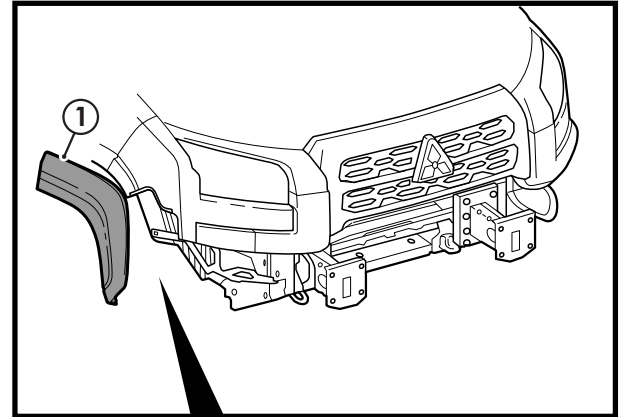

DO NOT DRILL THROUGH FLARE CAP OUTER SURFACE

- Apply a bead of black Sikaflex into the Flare cap channel.
- Fit the fender flare cap to the flare.
- Fix in place with the supplied self-tapper screw (5).
- Repeat for LHS.

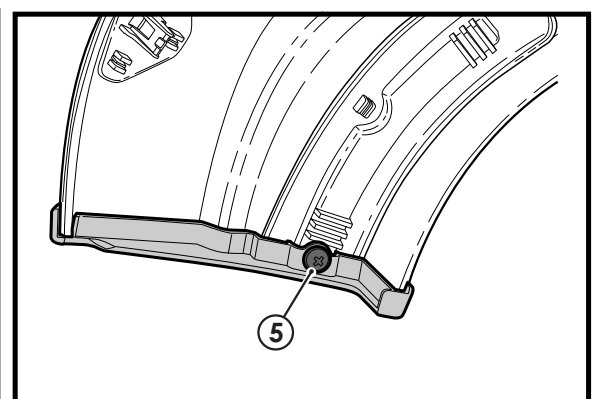
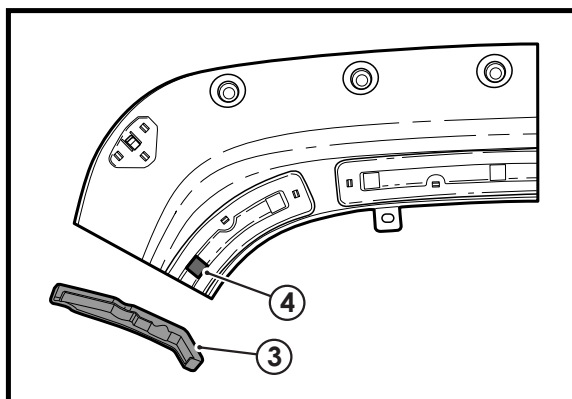
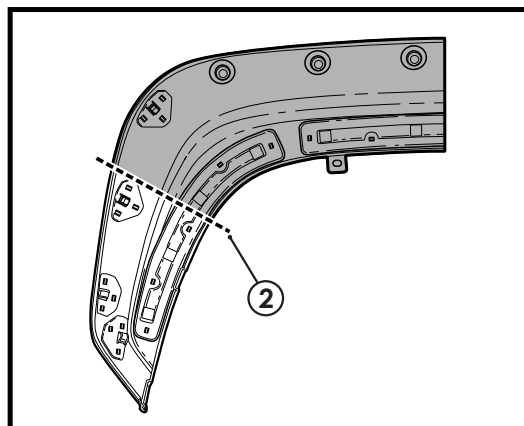
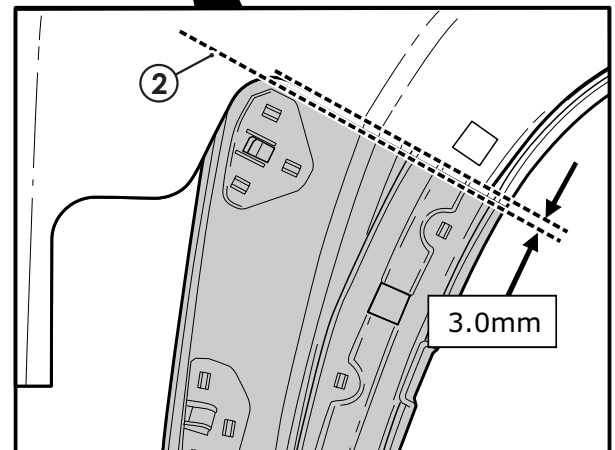

Tools Required:

- Marker pen
- Multi tool
- Deburrer
- Power drill & 2.0mm drill
- Sikaflex
- Phillips head screwdriver