

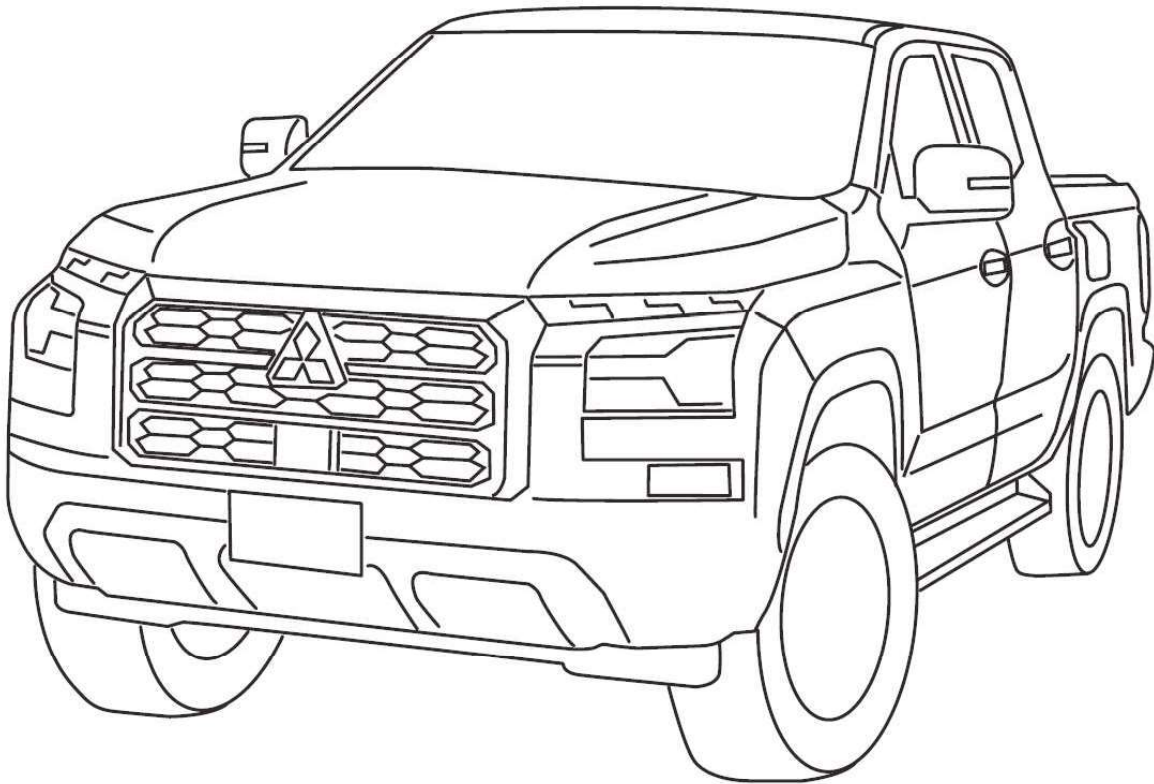







Side Protection Bar

Installation and Owner's manual

LA0 Parts No. MZ350772

- Thank you for purchasing the Mitsubishi Motors genuine accessory.
- The initial installation quality determines the level of performance, durability and trouble occurrence in the future.
- Make sure to read this manual carefully before installation of the product, and install it correctly after understanding an overall operation flow. Do not attempt installation other than instructed in this manual. We shall not be responsible for an failures occurred by not following the instructions in this manual.
- We recommend you to have the installation performed at an authorized Mitsubishi Motors dealer to ensure the reliability.

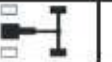

								
MZ350772	✓	×	×	×	✓	✓	✓	N/A

Symbol meaning

 **Warning**

This symbol indicates a particularly important safety instruction. Read and follow it carefully for safety. Failure to heed the caution may result in death or serious human injuries.

 **Caution**

This symbol indicates a particularly important safety instruction. Read and follow it carefully for safety. Failure to heed the caution may result in human injuries or accidents.

 **Note**

This symbol indicates an advisory instruction to follow during installation and handling.

Precautions for installation











Warning





Perform the installation indoors that is large enough without worrying about the rain and wind. Make sure the work area is well ventilated and take special care for the fullness of exhaust gas.

- Do not install to the vehicles except for the applicable types.
- Do not install with remodeling. Failure to heed this caution may result in serious accidents.

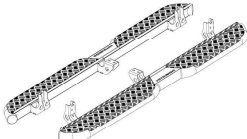
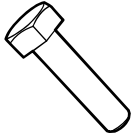

Caution

	Work carefully using a protective cover to prevent the vehicle from scratches and dirt.		Wipe off the dirt of the product using a sponge with a neutral detergent. Do not use organic solvents such as thinner, acids and alkalis.
	When removing and reinstalling the vehicle body parts, refer to the vehicle's workshop manual.		When installing the parts and reinstalling the removed vehicle body parts, be careful not to let vehicle harnesses be caught and pinched between parts.
	Be careful not to make a mistake when reinstalling the clips, screws, etc. removed from the vehicle.		When jacking up the vehicle, make sure to use wheel chocks and work on a flat place.
	Remove dirt and oil on the surface where the parts are installed with a tape or double-sided tape completely.		Tighten securely parts which the tightening torque is indicated according to the specified torque.
	When removing connectors, hold the connector bodies and unlock without pulling on harnesses. Do not destroy the connector lock by prying with a screw driver. Keep the harnesses away		Do not pull on wiring harnesses strongly.

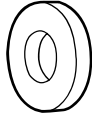
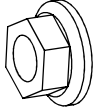
● **COMPONENTS** (Make sure that all of the following components are included in the kit.)

<p>① Side Protection Bar LH & RH: 1</p> 	<p>② M8 x 25 Hex Bolt: 8</p> 	<p>③ M8 Spring Washer: 8</p> 	<p>④ M8 Flat Washer: 8</p> 	<p>⑤ M8 Serrated Flanged Nut: 4</p> 
---	--	--	--	---

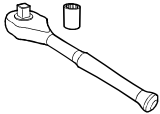
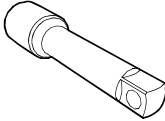
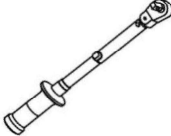
● **TOOLS** (Make the following tools ready for use.)

<p>Socket wrench (13)</p> 	<p>Extension bar</p> 	<p>Torque wrench</p> 	<p>Cloth</p> 	
---	--	--	---	--

● **PRECAUTIONS**

- Make sure to refer to statements in a circular box in the installation instructions as they highlight particularly important points.
- Refer to the vehicle's workshop manual when removing and refitting vehicle components.
- Take special care not to damage the vehicle during installation.
- Ensure vehicle is free of any stain or oil and fats completely at the installation area of the accessory prior to fitment.
- When refitting vehicle parts, be careful not to let vehicle harnesses be pinched between parts.

● **LAYOUT**

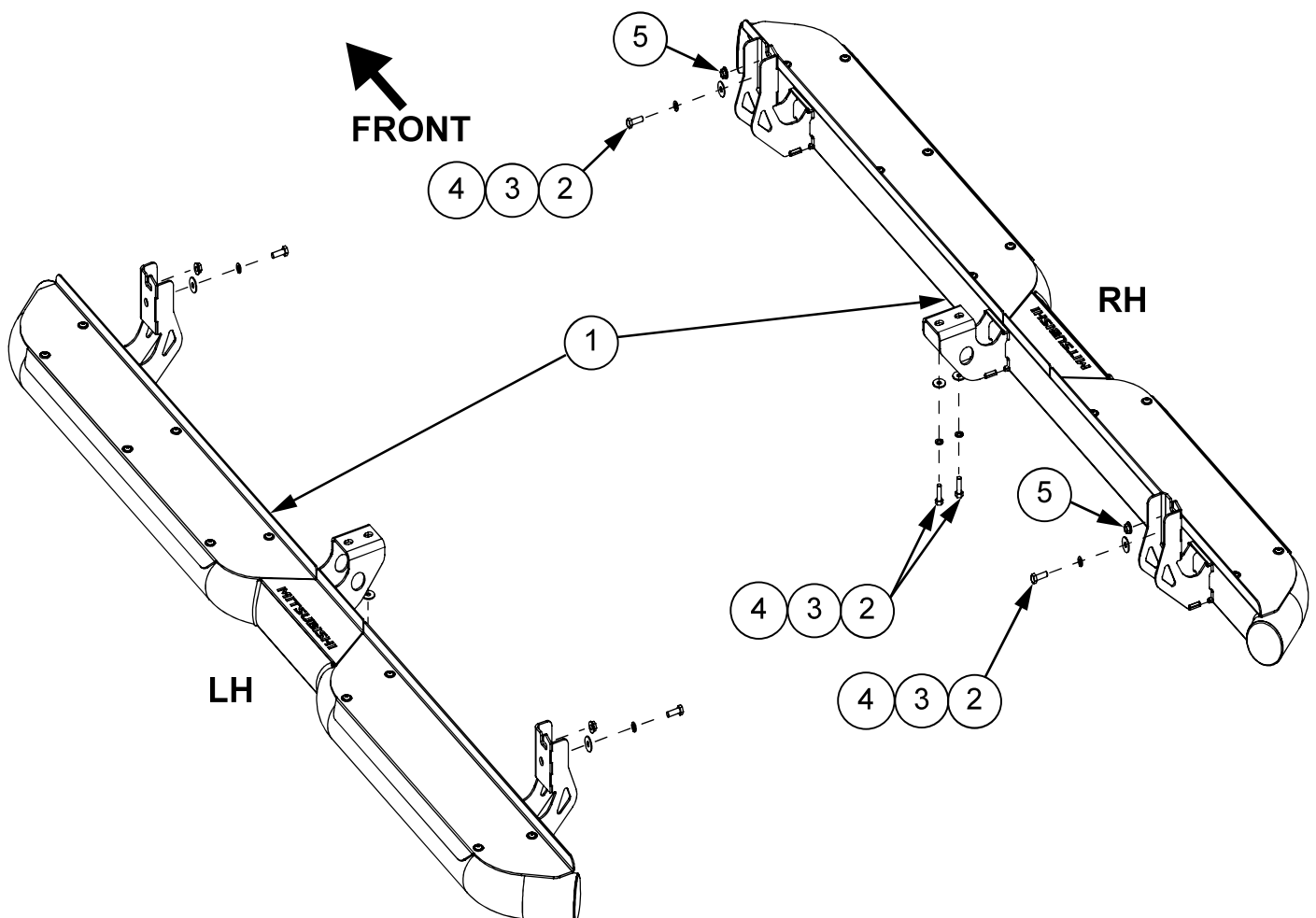

INSTALLATION PROCEDURES

A. Removal of vehicle parts

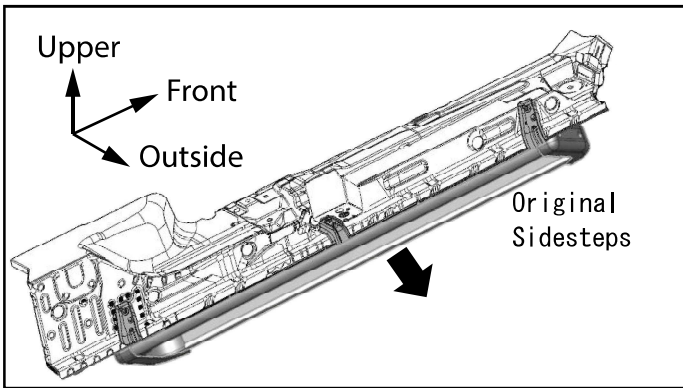

1) If the vehicle is fitted with sidesteps, remove and discard the original sidesteps and fasteners.

Note

- Refer to vehicle's workshop manual for how to remove vehicle parts.
- Do not lose other parts because they will be reused.

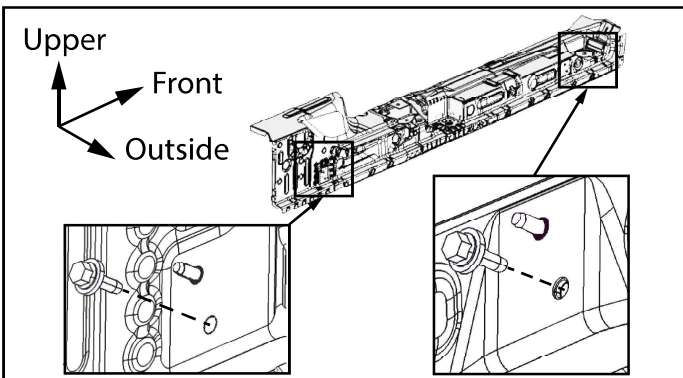

2) If the vehicle is not fitted with sidesteps, remove and discard two bolts on LHS.

3) Repeat for RHS.

Note

- Refer to vehicle's workshop manual for how to remove vehicle parts.
- Do not lose other parts because they will be reused.

INSTALLATION PROCEDURES

B. Attaching the Side Steps

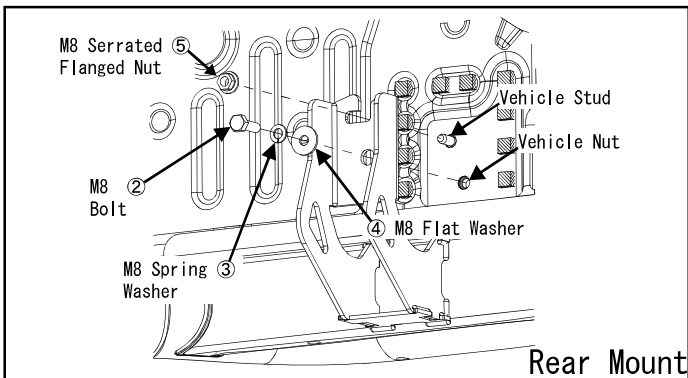
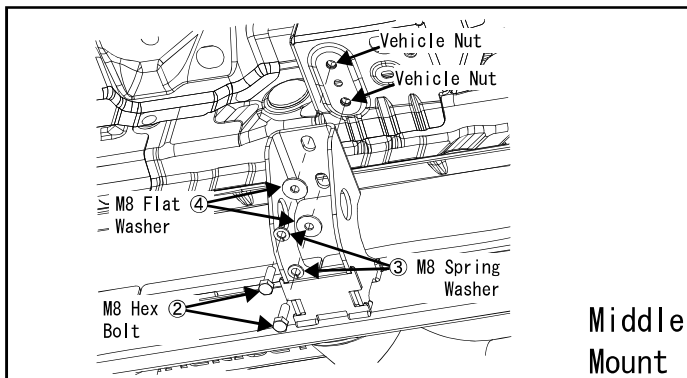
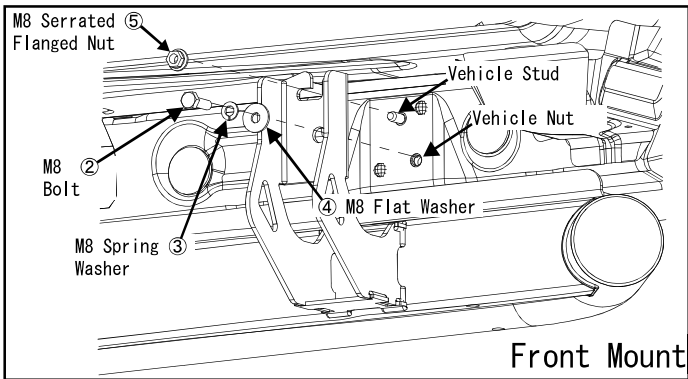

- 1) Offer the ① side protection bars to the same position where the original sidesteps were mounted. Locate side protection bars on front and rear vehicle studs.
- 2) Loosely install ⑤ M8 flange nuts onto the vehicle studs at the front and rear side protection bar mounts.
- 3) Loosely install ② M8 bolts, ③ M8 spring washers and ④ M8 flat washers into the vehicle nuts through each side protection bar mount.
- 4) Ensure side protection bars are correctly positioned. Adjust as required.
- 5) Torque LH side protection bar fasteners in the following sequence:
 - 2x ② M8 Hex Bolts to 20 ~ 24 Nm (middle mounts)
 - 2x ⑤ Flanged Nuts to 16 ~ 20 Nm (front and rear mounts)
 - 2x ② M8 Hex Bolts to 20 ~ 24 Nm (front and rear mounts)Repeat for RHS.

Warning

It is recommended to retighten all fixing points in accordance with prescribed tightening sequence in this fitting instruction after the side protection bar has been in use for approximately 1000km



0km --> 1000km