

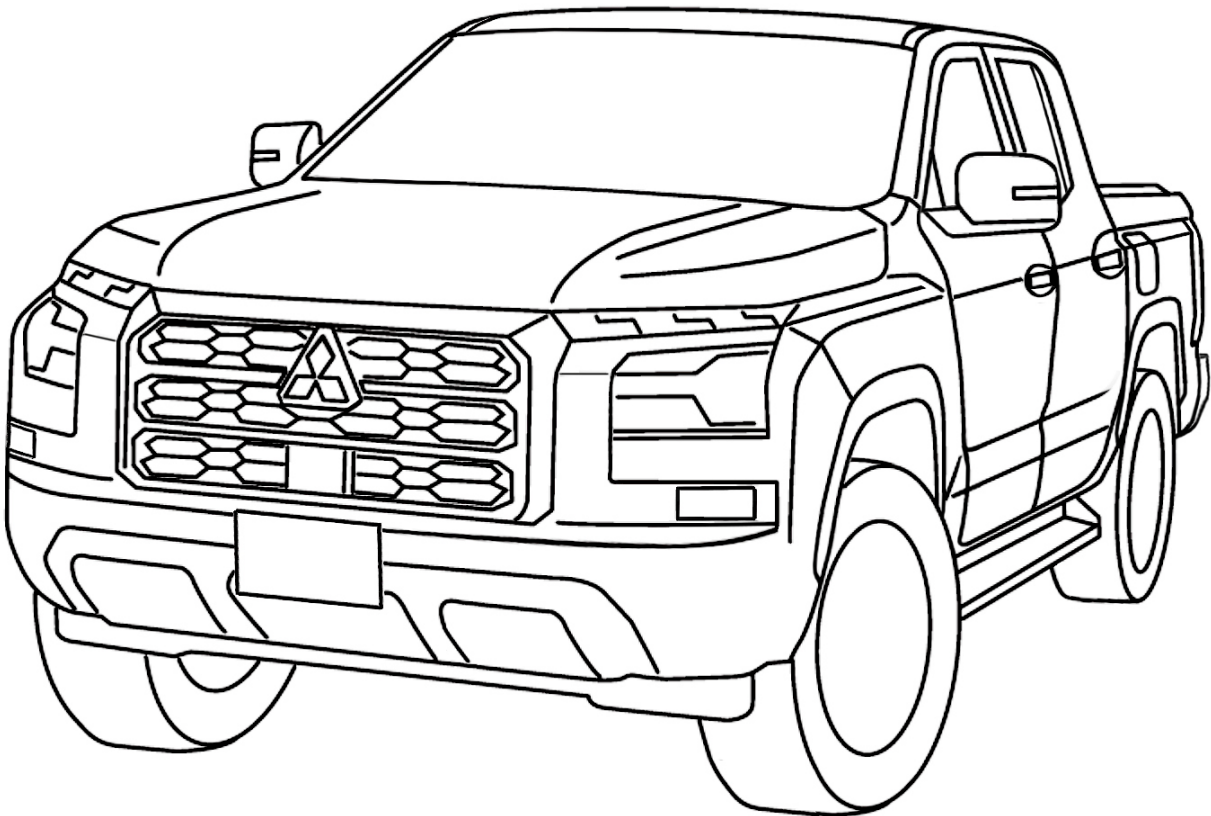







Tonneau Cover (Without Sports Bar)

Installation and Owner's manual

LA0 – Parts No. MZ350795

- Thank you for purchasing the Mitsubishi Motors genuine accessory.
- The initial installation quality determines the level of performance, durability and trouble occurrence in the future.
- Make sure to read this manual carefully before installation of the product, and install it correctly after understanding an overall operation flow. Do not attempt installation other than instructed in this manual. We shall not be responsible for any failures occurred by not following the instructions in this manual.
- We recommend you to have the installation performed at an authorized Mitsubishi Motors dealer to ensure the reliability.



								
MZ350795	✓	✓	x	x	✓	✓	✓	x

Symbol meaning

 **Warning**

This symbol indicates a particularly important safety instruction. Read and follow it carefully for safety. Failure to heed the caution may result in death or serious human injuries.











 **Caution**

This symbol indicates a particularly important safety instruction. Read and follow it carefully for safety. Failure to heed the caution may result in human injuries or accidents.

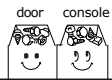
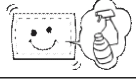
 **Note**

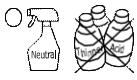
This symbol indicates an advisory instruction to follow during installation and handling.

Precautions for installation

 Warning	
	Perform the installation indoors that is large enough without worrying about the rain and wind. Make sure the work area is well ventilated and take special care for the fullness of exhaust gas.
<ul style="list-style-type: none"> Do not install to the vehicles except for the applicable types. Do not install with remodeling. Failure to heed this caution may result in serious accidents. 	
 Caution	
	Work carefully using a protective cover to prevent the vehicle from scratches and dirt.
	When removing and reinstalling the vehicle body parts, refer to the vehicle's workshop manual.
	Be careful not to make a mistake when reinstalling the clips, screws, etc. removed from the vehicle.
	Remove dirt and oil on the surface where the parts are installed with a tape or double-sided tape completely.
	When removing connectors, hold the connector bodies and unlock without pulling on harnesses. Do not destroy the connector lock by prying with a screw driver. Keep the harnesses away.
	Wipe off the dirt of the product using a sponge with a neutral detergent. Do not use organic solvents such as thinner, acids and alkalis.
	When installing the parts and reinstalling the removed vehicle body parts, be careful not to let vehicle harnesses be caught and pinched between parts.
	When jacking up the vehicle, make sure to use wheel chocks and work on a flat place.
	Tighten securely parts which the tightening torque is indicated according to the specified torque.
	Do not pull on wiring harnesses strongly.

— PARTS SUPPLIED

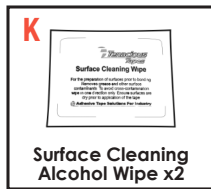
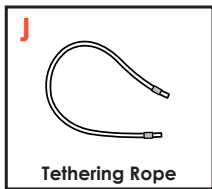
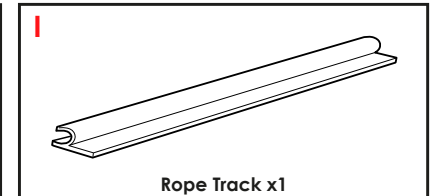
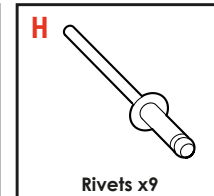
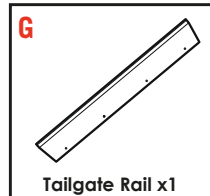
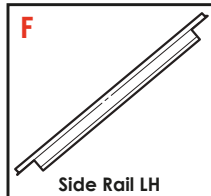
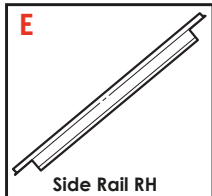
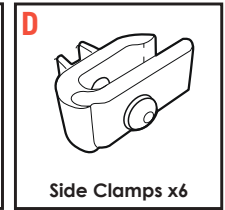
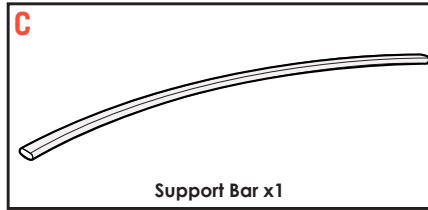
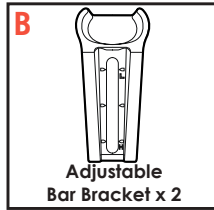
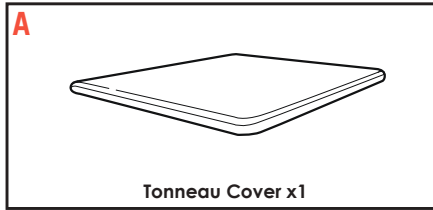

— SAFETY NOTES

- Ensure that appropriate Personal Protective Equipment is used.
- During the accessory fitment, ensure all Australian automotive and dealership safety practices are followed.
- Always refer to the vehicle's workshop manual when removing components.
- Never use a powered drill to screw the bolts. Always do this by hand with the tool provided to prevent damage to the fasteners.



— FINAL ASSEMBLY

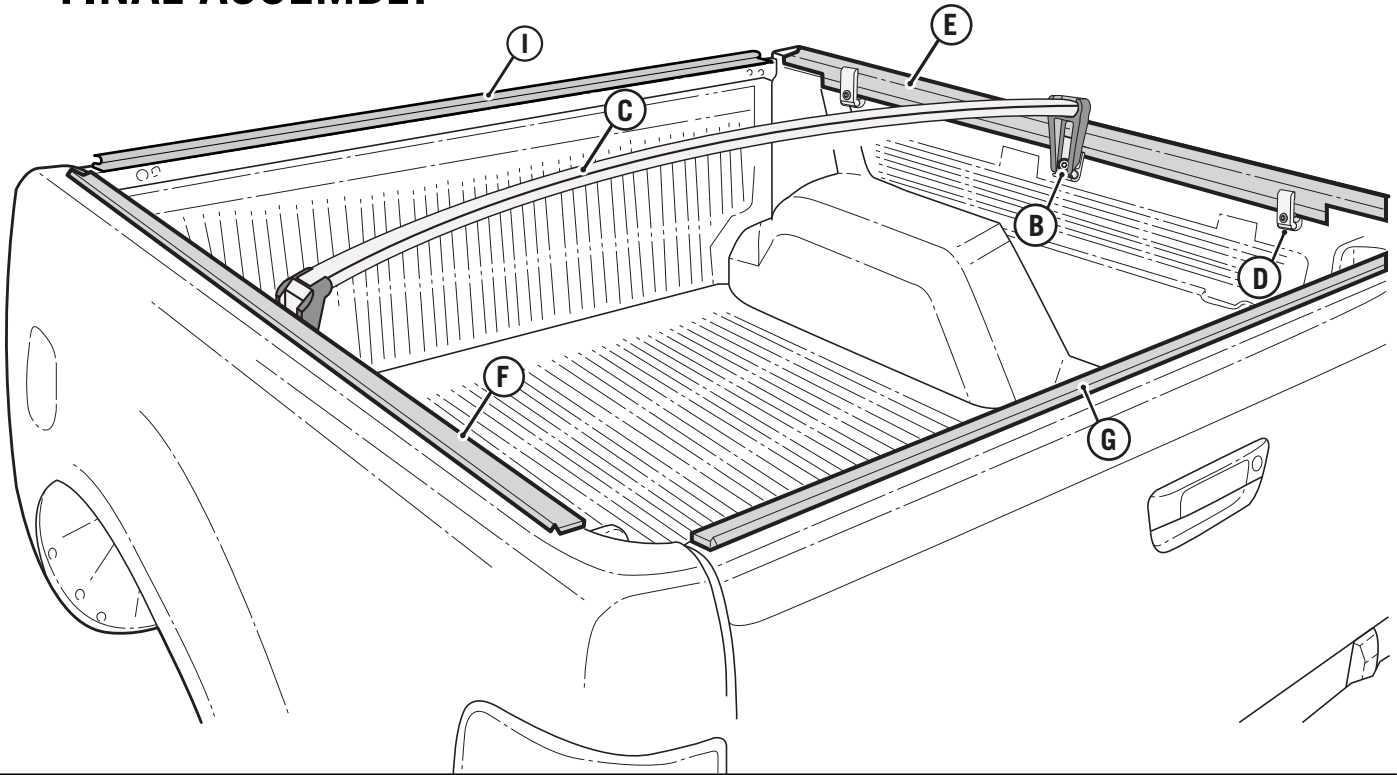

1 ATTACHING THE ROPE TRACK

- Align the opening of the rope track ① with the front of the tub.
- Center the rope track into position.
- Mark the 5 hole positions on the tub using the rope track as a template with equal spacing and then drill 5 holes using a 4.2mm drill bit.
- Clean with surface cleaning wipe ⑫. Carefully apply rust preventative ⑬ into drilled holes.
- Remove the backing from double sided tape and place it into position.
- Rivet rope track into place using rivets ④.

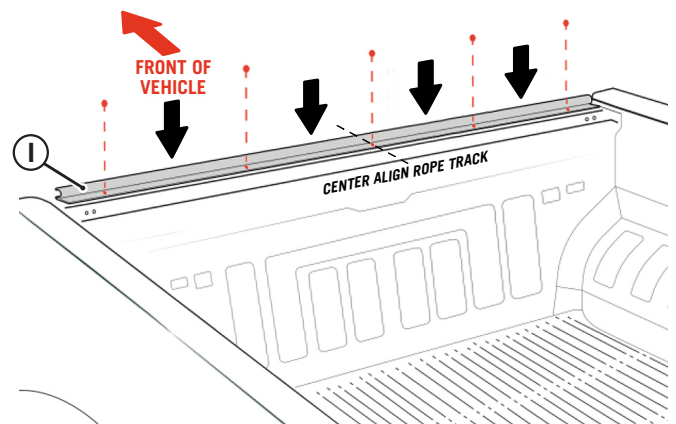
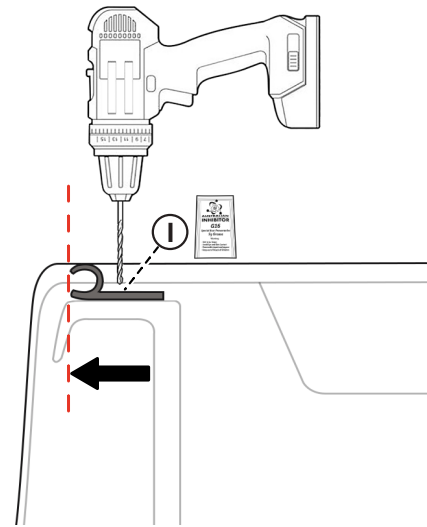

2 ATTACH THE SIDE RAILS

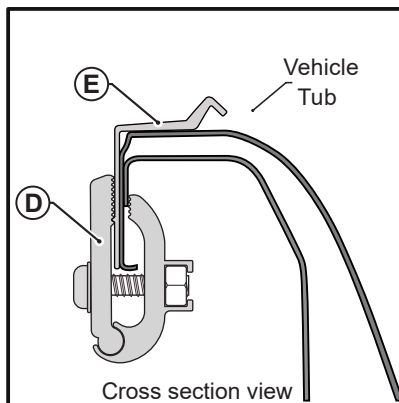
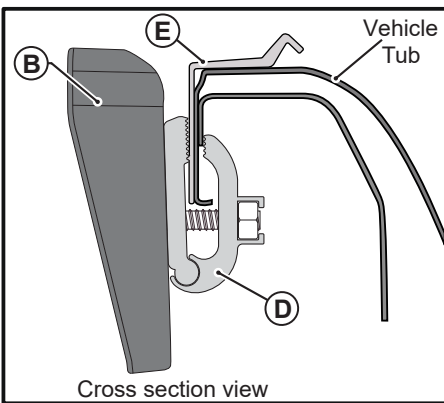
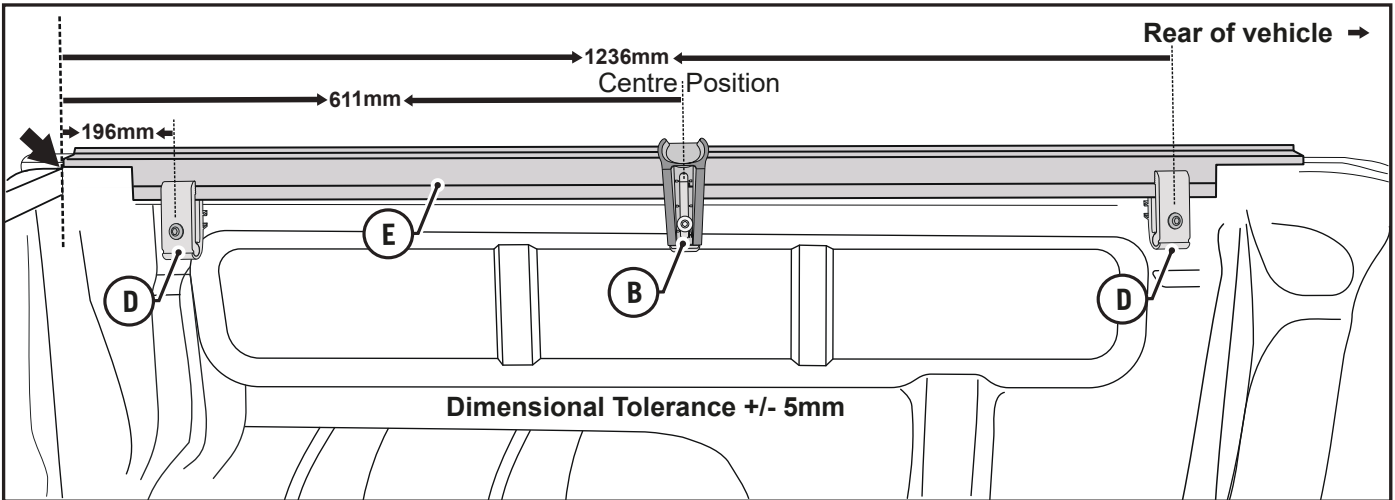

- Place the side rail (E) flush as shown above
- Attach rear side clamp (D) first at 1236mm, and another one a 196mm from the front inner corner of the tub, pressing the side rail down onto the body.
- Attach the adjustable bar bracket (B) along with side clamp at 611mm from the front inner corner of the tub.
- Repeat for LHS with side rail (F).

Important



The side clamps (D) need to be placed and engaged as high as possible to ensure good grip on sheet metal.

3 FIT THE SUPPORT BAR.

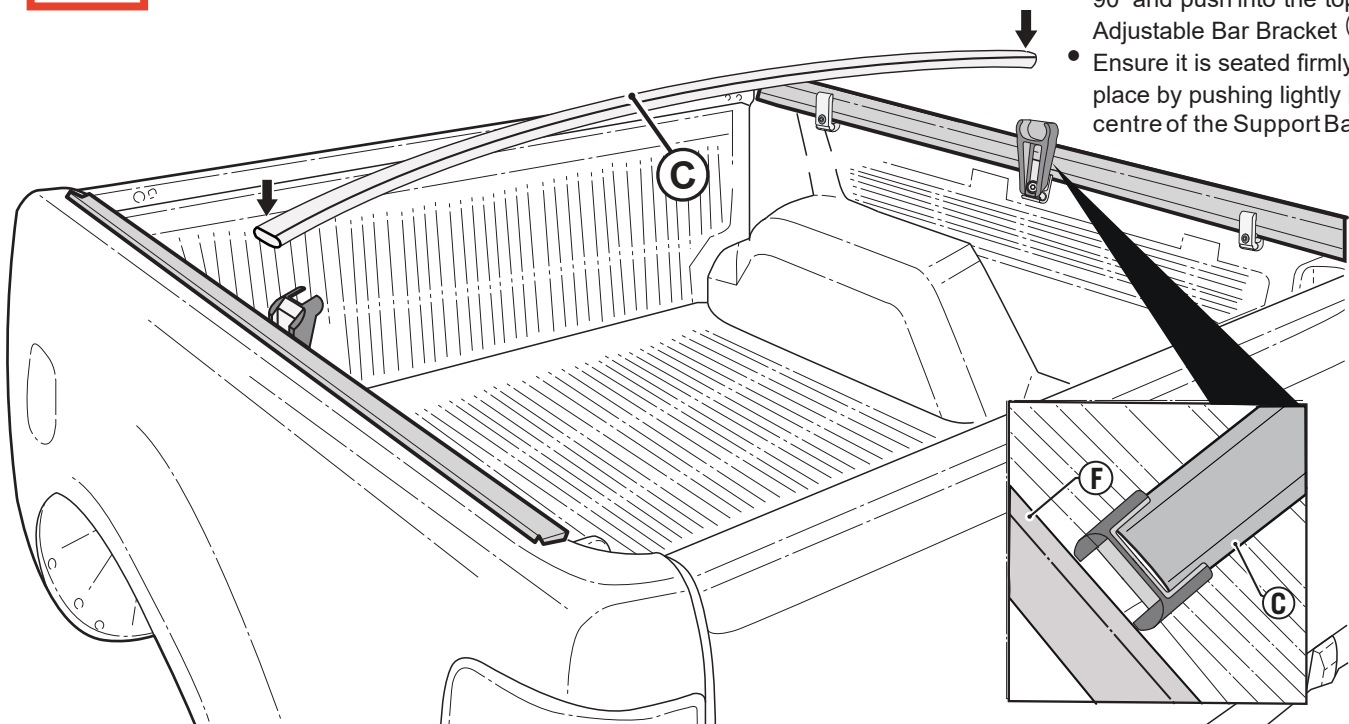

- Rotate the Support Bar (C) 90° and push into the top of the Adjustable Bar Bracket (B).
- Ensure it is seated firmly into place by pushing lightly in the centre of the Support Bar (C).

4 ATTACH THE TAILGATE RAIL

STEP 4.1

- Remove the Tailgate Liner & Strip (if fitted).

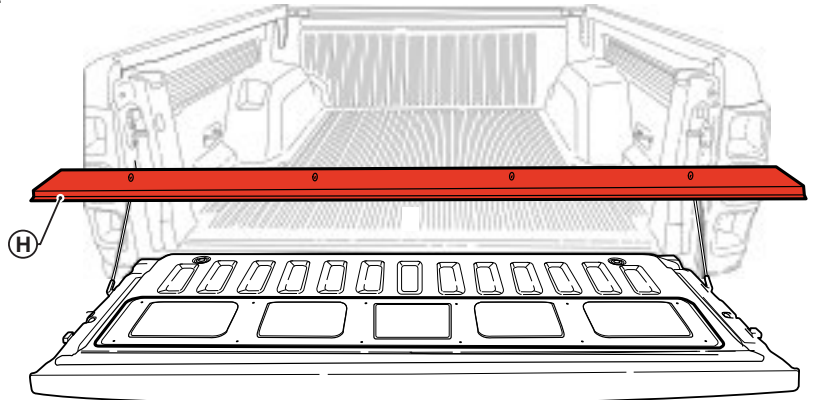

Important - Caution not to damage tailgate liner double sided tape, as it will need to be re-used.

STEP 4.2

- Center the rail and align the inside edge of the rail, then mark 4 holes using the tailgate rail as template for drilling holes. Use a 4.2mm drill bit to drill the holes at each of the 4 holes on the tailgate rail through the aluminium and into the tailgate.
- Carefully apply rust preventative into drilled holes.

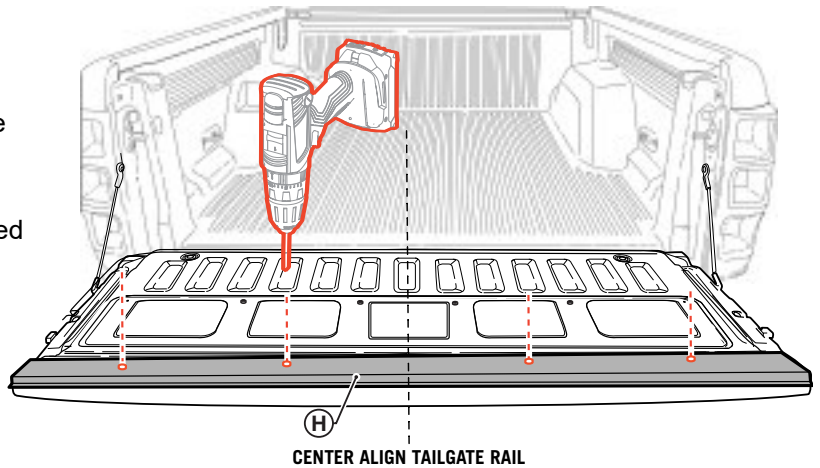

STEP 4.3

- Clean the top edge of tailgate with alcohol wipe .
- Remove the red backing tape from the underside of the tailgate rail , then center the rail and align the inside edge of the rail with the inside edge of tailgate. Align holes on the tailgate rail to that of the drilled holes on the tailgate and firmly press down.
- Rivet the holes with rivets , securing the rail onto the inside edge of the tailgate.

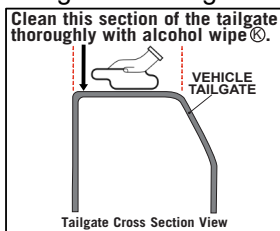
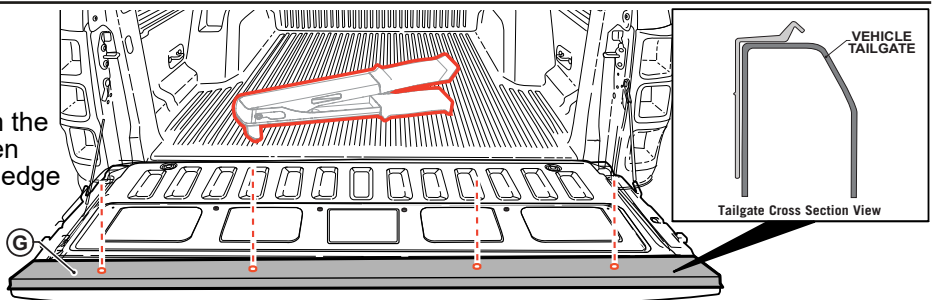

With Tailgate Liner
Finished Appearance

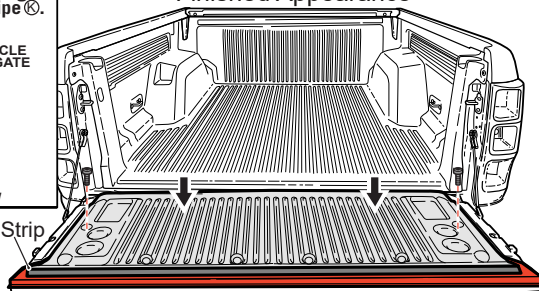

No Tailgate Liner
Finished Appearance

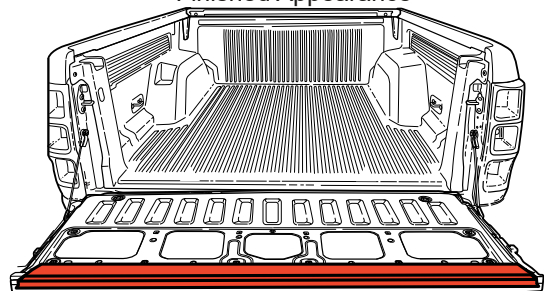

Important - Alcohol wipe tailgate rail for re-attachment of tailgate liner double sided tape.

- Fit edges of the tailgate liner into original position and re-install original screws to secure the liner on top of the tailgate rail .

5 TETHERING METHOD (This step is carried out in combination with the 6th step.)

- Use the tethering rope ① to do a Fisherman's knot with the second set of front loops in the tonneau cover as shown.

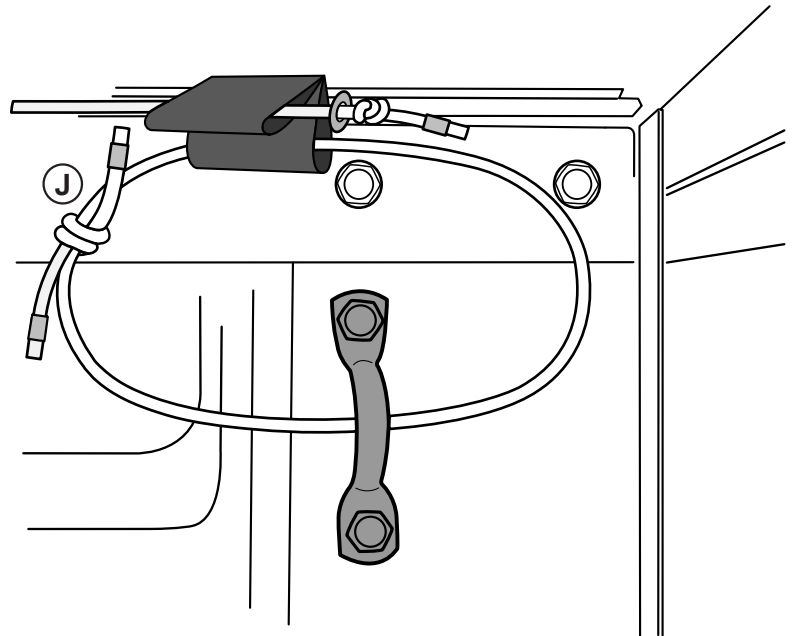
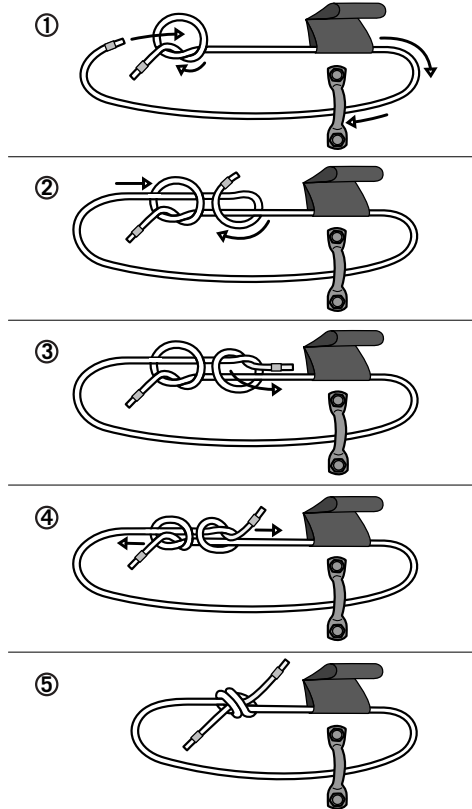

- This tethering step is to be repeated for both the front corners.

6 FIT THE TONNEAU COVER

- Place the front of the cover ① in-between the tub & cab and lock the plastic J Retainer into the rope track.
- Engage the back of the cover first on the tailgate rail, followed by the sides. Use the pull tabs to help pull the cover into place.

Note: Ensure the support bar is fitted underneath the Tonneau Cover to prevent water ingress and to keep the cover tight.



Use the pull tabs to assist whenever you open or close your cover.

Note: Fitment will be tight straight out of the box, but this should loosen up a little after a week or so.

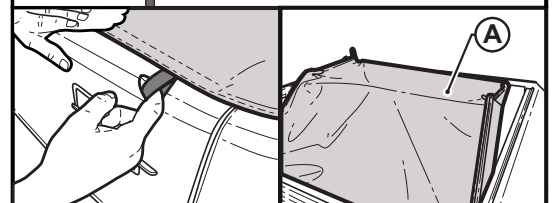
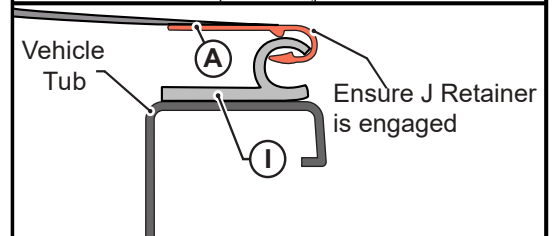
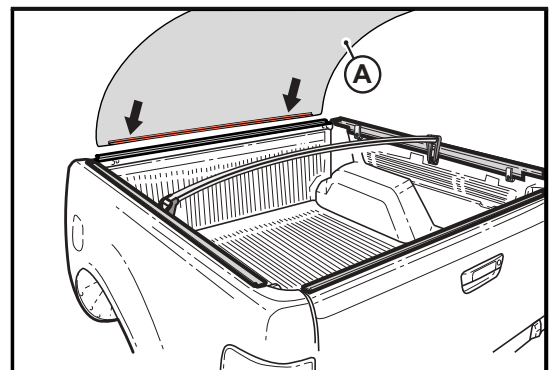

ADJUSTING THE TENSION OF THE COVER

- To adjust the tension of the cover, you must adjust the height of the support bar. To do this, we have designed a patented adjustable bracket system which will allow you to freely adjust the height to any position within the range of the bracket.
- Simply loosen the bolt which goes through the Bar Bracket (B) and Clamp (D) then move the bracket either up or down until the bolt is at your desired level. Re-tighten the bolt.
- Your Adjustable Bar Bracket has a large tension range.
 - “L” lowers the height and loosens the cover.
 - “H” increases the height and tightens the cover.

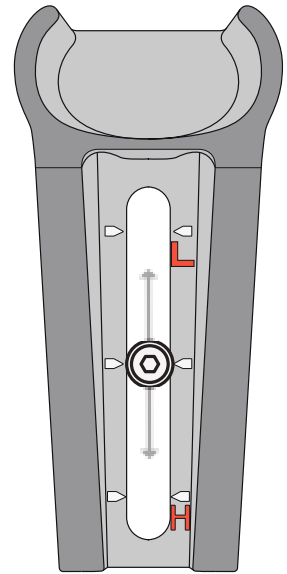
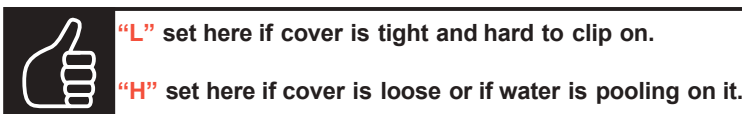

INSTALLATION OF THE Tonneau COVER IS COMPLETE!

HOW TO USE THE OVERSIZED LOAD SYSTEM

STEP 1

- Place the load into the ute tub then drape the tonneau cover over it as shown.

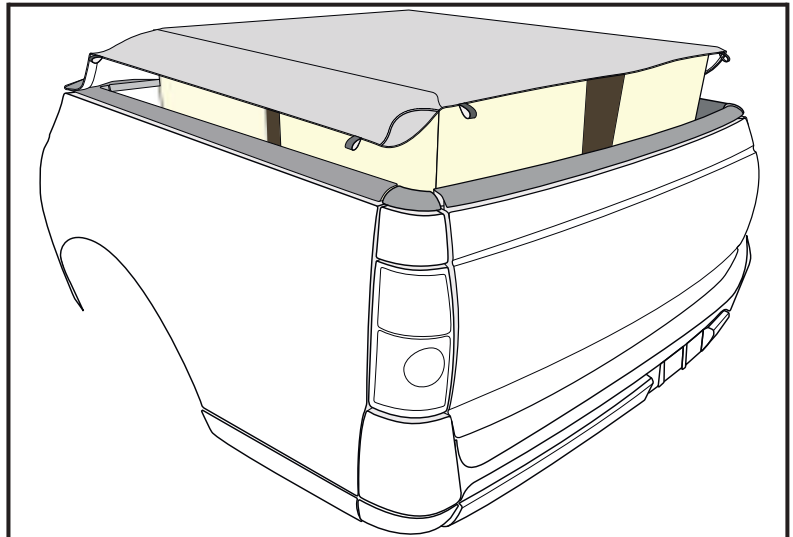

STEP 2

- Engage the Rope Hooks from underneath the Tonneau Cover and clip each one onto the Tub Rail.

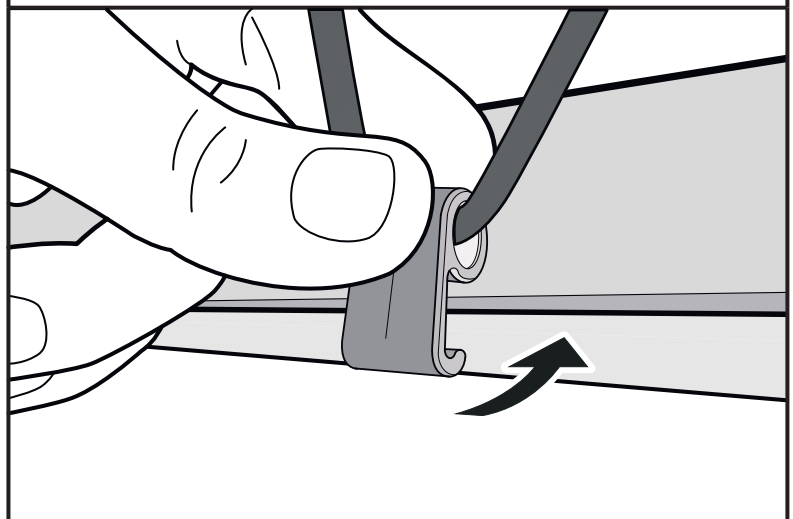

STEP 3

- Engage all Rope Hooks for a secure fit.

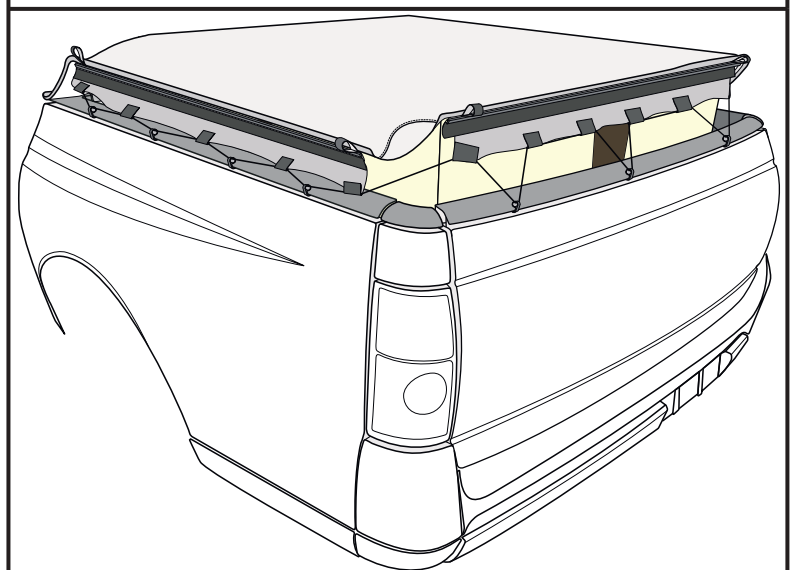

Important



The Tonneau Cover is not designed to be a load restraint. You **MUST** securely tie down your load first and then use the Oversized Load Cover System.